

JOINT INSTITUTE FOR NUCLEAR RESEARCH

The Report on Project

“Studies of Baryonic Matter at the Nuclotron (BM@N)”

02-0-1065-2007/2023

LEADER

M.N.Kapishin

Submitted

LHEP Science and Technology Council

LIST OF PARTICIPANTS FROM JINR AND MEMBER-STATES

Joint Institute for Nuclear Research – JINR (Dubna), FTE = 82

K. Abraamyan, S.V.Afanasiev, G.N.Agakishiev, I.N. Aleksandrov, E.I. Aleksandrov, K.A. Alishina, T. Atovullaev, V.A.Babkin, V.P. Balandin, N.A.Balashov, D.A.Baranov, P.N.Batyuk, M. Baznat, S.N.Bazylev, M.G.Buryakov, D.N.Bogoslovsky, V.E. Burtsev, S.G. Buzin, A.I. Chebotov, B.Dabrowska, D.V. Dementev, A.V.Dmitriev, D.K.Dryablov, P.O. Dulov, D.S.Egorov, V.V. Elsha, A.A.Fediunin, I.A.Filippov, I.A. Filozova, I.R. Gabdrakhmanov, O.P.Gavrishchuk, K.V.Gertsenberger, V.M.Golovatyuk, M.N.Kapishin, V.Yu.Karjavin, R.R.Katabekov, V.D.Kekelidze, S.V.Khabarov, Yu.T.Kiryushin, V.I.Kolesnikov, A. Kolozhvari, Y.A.Kopylov, A.D. Kovalenko, Y.S. Kovalev, E.M.Kulish, S.N.Kuklin, A.Kuznetsov, E.A.Ladygin, N.A. Lashmanov, V.V.Lenivenko, E.I.Litvinenko, S.P.Lobastov, A.M. Makan'kin, A.I.Maksymchyuk, A.I.Malakhov, G.J.Musulmanbekov, S.P.Merts, A.N.Morozov, Yu.A.Murin, R.V.Nagdasev, D.N.Nikitin, D.A.Oleynik, V.V.Palchik, M.A.Patsyuk, Yu.P.Petukhov, A. Petrosyan, S.M.Piyadin, V.A.Plotnikov, D.Podgainy, Yu.K.Potrebenikov, O.V.Rogachevsky, V.Yu.Rogov, P.A.Rukoyatkin, I.A.Rufanov, M.M.Rumyantsev, D.G. Sakulin, S.A.Sedykh, S.V.Sergeev, A.D.Sheremetev, A.I.Sheremeteva, A.V. Shchipunov, M.O.Shitenkov, A.V.Shutov, V.B.Shutov, I.V.Slepnev, V.M.Slepnev, I.P.Slepov, A.S.Sorin, V.N.Spaskov, E.A.Streletskaaya, O.I.Streltsova, N.V.Sukhov, D.A.Suvarieva, N.A. Tarasov, O.G.Tarasov, A.V.Terletsky, V.V.Tikhomirov, A.A. Timoshenko, O.V.Teryaev, N.D.Topilin, B.L. Topko, Yu.Topko, I.A.Tyapkin, V.A.Vasendina, A.V.Vishnevskiy, A.Voronin, N.Voytishin, V.I.Yurevich, N.I.Zamiatin, M. Zavertyaev, A.I.Zinchenko, V.N.Zhezher, E.V.Zubarev, M.I.Zuev

Institute for Nuclear Research RAS (Moscow)

A.I.Baranov, D. Finogeev, D.Gerasimov, M.B.Golubeva, F.F.Guber, A.P.Ivashkin, A.V. Izvestnyy, N.M.Karpushkin, A.Makarov, A.I. Makhnev, S.V.Morozov, O.A.Petukhov, A.I. Reshetin, E.Zherebtsova

Institute for Theoretical Experimental Physics – ITEP (Moscow)

P. Alekseev, D.Yu.Kirin, I.Larin, V.Semyachkin, A.V.Stavinsky, V.Tarasov, N.Zhigareva

Skobeltsyn Institute of Nuclear Physics Moscow State University (Moscow)

A. Baranov, N. Baranova, G. Bogdanova, E. Boos, D. Karmanov, P. Kharlamov, M. Korolev, I. Kovalev, I. Kudryashov, A. Kurganov, V. Kukulín, D. Lanskoj, V. Leontiev, M.M.Merkin, M. Platonova, A.Solomin, T. Tretyakova, V. Volkov, A. Voronin

Moscow Institute of Physics and Technology – MIPT (Moscow)

T.Aushev, P. Klimai

Moscow Engineering Physics Institute – MEPHI (Moscow)

E.Atkin, N.Barbashina, A.Bolozdynya, K.Filippov, A.Galavanov, V.Samsonov, I.Selyuzhenkov, P.Senger, V.Shumikhin, V.Sosnovtsev, M.Strikhanov, A.Taranenko

Kurchatov Inst. NRC, Moscow

D.Blau, D. Peresunko

SPbU, St Petersburg

A.Dryuk, S.Nemnyugin, V.Roudnev, M.Stepanova

Bulgaria

Plovdiv University "Paisii Hilendarski" (Plovdiv)

V.D.Tcholakov, L.Kovachev, M.Shopova, V.Kabadzhov

China

Key Laboratory of Nuclear Physics and Ion-Beam Application (MOE), Institute of Modern Physics, Fudan University, Shanghai

Y.Ma, J.Chen, S.Zhang

Czech republic

Nuclear Physics Institute, CAS, Řež

P.Chudoba, A.Kugler, V.Kushpil, S.Kushpil, V.Mikhaylov

Germany

GSI, Darmstadt

U.Frankenfeld, J.Heuser, R.Kapell, A.Lymanets, C.Schmidt, H.R.Schmidt, P.Senger, M.Teklishyn

Tubingen U., Tubingen

I.Panasenko, H.R.Schmidt, E.Volkova

Poland

Warsaw University of Technology, Faculty of Physics (Warsaw)

D. Dąbrowski, G. Kasproicz, A. Kisiel, M. Lawryńczuk, M. Linczuk, M. J. Peryt, S. Plamowski, J. Pluta, K. Poźniak, P. Rokita, R. Romaniuk, K. Roslon, T. Starecki, T. Traczyk, P. Wieczorek, D. Wielanek, W. Zabolotny

University of Wrocław, Wrocław

D. Alvear-Terrero, D. Blaschke, A. Ciszewski, R. Lewandkow, A. Sedrakian, O. Warmusz

Project leader:

M.Kapishin (JINR)

Project deputy:

A.Maksymchuk (JINR)

Content:

1. Introduction
2. Physical motivation: BM@N heavy-ion physics program
3. Detector for studies of Baryonic Matter at Nuclotron (BM@N)
 - 3.1 Main characteristics of the experimental setup
 - 3.2 BM@N performance and feasibility study
 - 3.2.1 BM@N performance in the first experimental runs
 - 3.2.2 Simulation of central tracker for heavy ion program
 - 3.3 Central tracker
 - 3.3.1 GEM tracker
 - 3.3.2 Forward silicon detectors
 - 3.3.3 STS tracker
 - 3.4 Outer tracker
 - 3.4.1 Cathode Strip chambers
 - 3.5 ToF system
 - 3.5.1 Start detector T0
 - 3.5.2 ToF-400 mRPC detector
 - 3.5.3 ToF-700 mRPC detector
 - 3.6 Calorimeters
 - 3.6.1 Forward hadron calorimeter FHCAL
 - 3.6.2 Fragment quartz hodoscope for FHCAL
 - 3.6.3 Calibration of the calorimeter modules with cosmic muons
 - 3.6.4 Development of a new approach to centrality determination by FHCAL
 - 3.6.5 Upgrade of the forward calorimeter system
 - 3.6.6 ECAL calorimeter
 - 3.7 Trigger system and beam detectors
 - 3.7.1 Trigger detectors
 - 3.7.2 Trigger electronics
 - 3.7.3 Silicon beam tracker
 - 3.7.4 Silicon beam profilometers
 - 3.8 Read-out electronics and DAQ system
 - 3.9 BmnRoot and data analysis software
 - 3.10 BM@N experimental zone
 - 3.10.1 Vacuum beam pipe within BM@N
 - 3.10.2 Radiation protection simulations
 - 3.10.3 Spectrometrical magnet
 - 3.10.4 Beam line to BM@N
 4. Estimated uncertainties and risks in the Project
 5. Estimated expenditures for the Project

1. Introduction

The theoretical and experimental investigation of the properties strongly interacting matter at high temperatures and densities is one of the most exciting research programs of modern high-energy nuclear physics. The recent astronomical observations of supermassive neutron stars and neutron star mergers challenge our knowledge on high-density QCD matter, like its equation-of-state (EOS) and its microscopic degrees-of-freedom at high baryon densities. Future measurements of mass and radius of neutron stars and the precise spectroscopy of gravitational waves will improve our understanding of the high-density EOS. Complementary information will be obtained by laboratory experiments with energetic heavy-ion collisions, which provide the opportunity to investigate both the EOS at high density, and to explore the degrees-of-freedom of this matter, including the search for new phases of high-density matter, which possibly feature characteristic structures like critical points. The investigation of the QCD phase diagram is a worldwide endeavor undertaken at heavy-ion accelerators like LHC and SPS at CERN, RHIC at BNL, and SIS18 at GSI. Future projects, like the “Facility for Antiproton and Ion Research” (FAIR) [1.1] in Darmstadt, Germany, and the “Nuclotron-based Ion Collider fAcility” (NICA) [1.2], will open unique possibilities to produce and explore QCD matter at densities, which are predicted to exist in the core of neutron stars. In particular, the fixed-target Compressed Baryonic Matter (CBM) experiment at FAIR [1.3], and the Multi-Purpose Detector (MPD) at the NICA collider [1.4] will focus on the investigation of diagnostic probes which are sensitive to the EOS and the degrees-of-freedom of high-density QCD matter. The existing Baryonic Matter @Nuclotron (BM@N) [1.5] experiment will be upgraded, in order to investigate heavy-ion collisions at beam energies up to about 4A GeV, where the fireball is predicted to be compressed to about 4 times saturation density.

2. Physical motivation: BM@N heavy ion physics program

The future Nuclotron beams are well suited to produce dense nuclear matter in the collision of heavy nuclei. In central Au + Au collision at top Nuclotron beam energies, densities of 4 -5 times saturation densities will be reached in the center of the reaction volume [2.1], corresponding to the densities prevailing in the core of neutron stars. Like matter in compact stellar objects, the matter in this fireball will be compressed according to the equation-of-state (EOS), and experiments at the Nuclotron, but also at NICA and at FAIR may shed light on the properties of neutron stars. These laboratory experiments complement astronomical observations of mass and radii of neutron stars, in order to determine the high-density EOS. Laboratory measurements, however, might be also sensitive to the degrees-of-freedom of dense nuclear, which are expected to change with increasing density, when the nucleons overlap and start to melt into their elementary constituents. Moreover, heavy-ion experiments may also provide information on the role of hyperons in neutron stars. The main aspects of the physics program of the BM@N experiment and the relevant observables will be discussed in the following.

2.1 The Nuclear-Matter Equation-of-State

The nuclear matter equation-of-state (EOS) relates thermodynamic properties like pressure, volume, temperature etc., and can be written as the energy per nucleon as a function of density:

$$E_A(\rho, \delta) = E_A(\rho, 0) + E_{\text{sym}}(\rho) \cdot \delta^2 + O(\delta^4)$$

where the first term represents the EOS for symmetric matter, and the second term is the symmetry energy with $\delta = (\rho_n - \rho_p)/\rho$ the isospin asymmetry parameter. The EOS of symmetric matter is commonly parameterized by the binding energy per nucleon at saturation density ρ_0 and the incompressibility K_{nm} , which corresponds to the curvature around ρ_0 . Several versions of the EOS for symmetric matter are represented by the lower curves in figure 2.1 [2.2]. The EOS for neutron matter is represented by the upper curves in figure 2.1, and the difference between the upper and lower curves for each EOS is the symmetry energy E_{sym} .

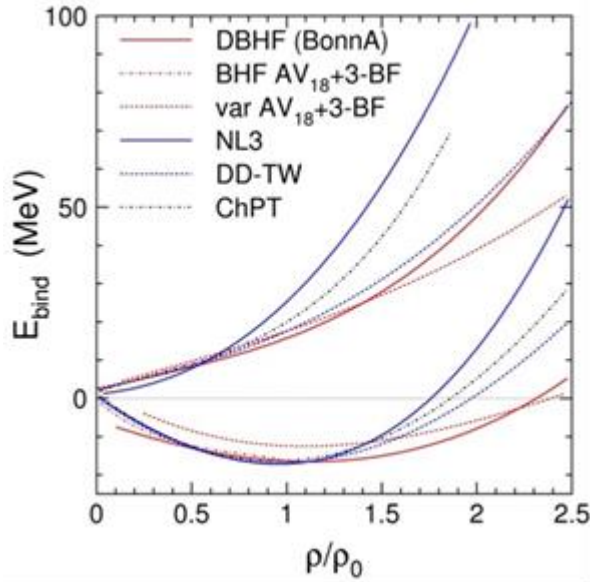

Fig. 2.1: Different versions of the equation of state for isospin-symmetric nuclear matter (lower curves) and for neutron matter (upper curves). For more information see [2.2].

Experiments at GSI have been performed by the FOPI collaboration, which measured the elliptic flow of protons, deuterons, tritons, and ^3He in Au + Au collisions at beam kinetic energies between 0.4 and 1.5 A GeV [2.3]. The elliptic flow of particles is driven by the pressure gradient in the reaction volume, and, therefore, is sensitive to the EOS. The FOPI data have been interpreted by calculations using the isospin-dependent quantum molecular dynamics (IQMD) transport code [2.3]. It was found, that the data can be explained assuming a nuclear incompressibility of $K_{\text{nm}} = 190 \pm 30$ MeV, which corresponds to a soft EOS for symmetric nuclear matter up to nuclear densities of about 2-3 ρ_0 .

In order to contribute to our understanding of neutron stars, densities of 4-5 ρ_0 have to be produced and investigated. Even higher densities have been reached in experiments at the AGS in Brookhaven, which measured both the directed and the elliptic flow of protons in Au + Au collisions at energies between 2 and 11 A GeV [2.4]. It turned out, that the data on directed flow agree with the assumption of a soft EOS, whereas the elliptic flow data point towards a hard EOS [2.5]. In conclusion, the interpretation of these data did not much constrain the range of possible EOS at high densities, and one important goal of the BM@N research program is to improve these flow measurements.

An alternative approach to study the EOS of symmetric matter is to investigate subthreshold strangeness production in heavy-ion collisions. This method has been pioneered by the KaoS collaboration at GSI, which measured the excitation function of K^+ meson production in Au + Au and C + C collisions beam energies from 0.8 and 1.5 A GeV [2.6]. Please note, that the minimum energy to create a K^+ meson in nucleon-nucleon collisions, for example via the process $p+p \rightarrow K^+\Lambda p$, is 1.58 GeV. Therefore, at sub-threshold energies, strangeness has to be produced via multiple collisions involving pions and Delta resonances. These sequential collisions occur more frequently, if the baryon density is high, which means, that the EOS is soft. The EOS effects show up in the heavy Au+Au system, but are less pronounced in the small C+C system. The kaon yield ratio from Au+Au over C+C collisions clearly exhibits an enhancement towards lower beam energies, which is caused by a soft EOS with a nuclear incompressibility of $K_{\text{nm}} \approx 200$ MeV according to RQMD and IQMD transport calculations [2.7,2.8]. This result agrees with the elliptic flow measurements done by FOPI in the same energy range, covering baryon densities up to about twice saturation density.

Another very promising observable sensitive to the high-density EOS of symmetric matter is the excitation function of multi-strange (anti-)hyperons. According to transport models, Ξ and Ω hyperons are produced in sequential collisions involving kaons and Λ hyperons, and, therefore, are sensitive to the density in the fireball [2.9,2.10]. This sensitivity is expected to increase at beam

energies close to or even below the production threshold. For example, the production of a Ξ^- hyperon in a proton-proton collision $pp \rightarrow \Xi^- K^+ K^+ p$ requires a minimum proton energy of $E_{\text{thr}} = 3.7$ GeV. Nevertheless, Ξ^- hyperons can be produced in heavy-collisions via strangeness exchange reaction at energies above the lambda threshold of 1.6 GeV via lambda-lambda collisions $\Lambda^0 \Lambda^0 \rightarrow \Xi^- p$. Even Omega hyperons can be produced, when the Xi collides with another lambda $\Lambda^0 \Xi^- \rightarrow \Omega^- n$ or with a kaon $K^- \Xi^- \rightarrow \Omega^- \pi^-$. Therefore, the measurement of multi-strange hyperons will be a central goal of the BM@N research program at the Nuclotron.

2.2 Mixed Phases of QCD Matter

In central Au+Au collisions at top Nuclotron beam energies, baryon densities of more than 4-5 ρ_0 might be reached. At these densities, the nucleons may already partly overlap, and start to melt into their elementary constituents. The question is, which observable might be sensitive to this onset of deconfinement? At very high bombarding energies like at LHC, there is experimental and theoretical evidence for the creation of a deconfined phase, the so-called Quark-Gluon-Plasma (QGP). One of the arguments is, that the yield of all created hadrons can be perfectly explained by the statistical hadronization models, assuming chemical equilibrium in a fireball with a temperature of about 156 MeV and vanishing baryon-chemical potential [2.11]. In particular the observation, that also multi-strange (anti-) hyperons are equilibrated, although their scattering cross section with nucleons is small, has been interpreted as indication for a phase transition from partonic to hadronic matter, which drives the hyperons into equilibration [2.12]. The same observation was made for Pb+Pb collisions at a beam kinetic energy of 30A GeV at the SPS for a fireball temperature 138 MeV of and a baryon-chemical potential of 380 MeV [2.13]. At much lower beam energies, i.e. in Ar + KCl collisions at an energy of 1.76A GeV, most of the hadron yields are also compatible with the statistical model for a temperature of 76 MeV and a baryon-chemical potential of 800 MeV. The yield of Ξ^- hyperons, however, exceeds the model prediction by about a factor 24 ± 9 [2.14]. This high yield is generated by multiple collisions including strangeness exchange reactions in a hadronic environment, as discussed above. Obviously, the Ξ^- hyperons did not equilibrate, because the beam energy is too low to for a phase transition. The energies at the Nuclotron might be sufficiently high to see the onset of deconfinement. Therefore, the BM@N research program includes the measurement of the excitation function of multi-strange hyperons in Au + Au collisions in order to explore the onset of equilibration of multi-strange hyperons at high net-baryon densities.

2.3. Hyperons in Dense Nuclear Matter

The role of hyperons in neutron stars is still a puzzle. If the hyperon chemical potential in dense nuclear matter falls below the chemical potential of neutrons and protons, these particles will decay in to hyperons. This process is expected to occur in the core of neutron stars at densities above 4 – 5 ρ_0 , leading to a softening of the nuclear equation-of-state, and, hence, preventing the existence of high mass neutron stars. On the other hand, neutron stars with about twice the mass of our sun have been observed [2.15]. The hyperon chemical potential depends not only on the repulsive two-body hyperon-nucleon ΛN force, but also on the three-body repulsive ΛNN interaction, which becomes increasingly important at high densities [2.16]. Therefore, laboratory experiments devoted to the investigation of hyperon-nucleon interactions will shed light on the role of hyperons in neutron stars. One possibility to study these interactions is to discover new hypernuclei and to measure their lifetimes. According to statistical model and transport calculations, light hypernuclei and even double-lambda hypernuclei are abundantly produced in heavy-ion collisions at Nuclotron and NICA energies [2.17,2.18]. This opens the opportunity for the upgraded BM@N experiment, to measure light hypernuclei in Au+Au collision at the top Nuclotron beam energy, and to contribute to the solution of the long-standing hyperon puzzle in neutron stars.

References

- [1.1] <https://fair-center.de>
- [1.2] <https://nica.jinr.ru>
- [1.3] T. Ablyazimov et al., [CBM Collaboration] Eur. Phys. J. A 53 (2017) 60
- [1.4] V. Golovatyuk et al., Nucl. Phys. A 982 (2019) 963
- [1.5] M. Kapishin for the BM@N collaboration, Nucl. Phys. A 982 (2019) 967
- [2.1] I.C. Arsene et al., Phys. Rev. C 75, 24902 (2007)
- [2.2] C. Fuchs, arXiv:nucl-th/0610038
- [2.3] A. Le Fevre et al., Nucl. Phys. A 945 (2016) 112–133.
- [2.4] C. Pinkenburg et al., Phys. Rev. Lett. 83 (1999) 1295.
- [2.5] P. Danielewicz, R. Lacey, W.G. Lynch, Science 298 (2002) 1592.
- [2.6] C. Sturm et al. [KaoS Collaboration] Phys. Rev. Lett. 86 (2001) 39.
- [2.7] Ch. Fuchs et al., Phys. Rev. Lett. 86 (2001) 1974
- [2.8] C. Hartnack and J. Aichelin, J. Phys. G 28 (2002) 1649.
- [2.9] F. Li et al., Phys. Rev. C 85 (2012) 064902
- [2.10] G. Graef et al., Phys. Rev. C 90 (2014) 064909
- [2.11] A. Andronic et al., J. Phys. G38 (2011) 124081
- [2.12] P. Braun-Munzinger, J. Stachel and C. Wetterich, Phys.Lett. B 596 (2004) 61
- [2.13] A. Andronic, P. Braun-Munzinger and J. Stachel, Acta Phys. Polon. B 40 (2009) 1005
- [2.14] G. Agakishiev et al. [HADES collaboration] Eur. Phys. J. A 47 (2011) 21
- [2.15] H. T. Cromartie et al., Nat. Astron. 2019, doi:10.1038/s41550-019-0880-2.
- [2.16] W. Weise, arXiv:1905.03955v1, to appear in JPS Conf. Proc
- [2.17] A. Andronic et al., Phys. Lett. B 697 (2011) 203
- [2.18] A. S. Botvina et al., Phys. Lett. B 742 (2015) 7

3. Detector for studies of Baryonic Matter at Nuclotron (BM@N)

BM@N (Baryonic Matter at Nuclotron) is the first experiment at the accelerator complex of NICA Nuclotron. The schematic view of the NICA-Nuclotron complex and the position of the BM@N setup are presented in figure 3.1. The sources of light and heavy ions, the beam Booster, Nuclotron accelerator and NICA collider are shown. The heavy-ion physics program of the NICA accelerator complex and the MPD experiment planned at the NICA collider are described in [3.1-3.4]. The aim of the BM@N experiment is to study interactions of relativistic heavy ion beams with fixed targets [3.5]. The Nuclotron will provide variety of beams from protons to gold ions with the kinetic energy of ions ranging from 1 to 6 GeV per nucleon. The maximum kinetic energy for ions with the ratio of the charge to the atomic weight (Z/A) of $1/2$ is 6 GeV per nucleon. The maximum kinetic energy for heavy ions with the ratio of $Z/A \sim 1/3$ is 4.5 GeV per nucleon. The maximum kinetic energy of protons is 13 GeV. The beam line between the Nuclotron and the BM@N experiment is around 160 meter in length. It comprises 26 elements of magnetic optics: 8 dipole magnets and 18 quadrupole lenses. An upgrade program of the beam line is foreseen to minimize the amount of scattering material on the way of heavy ions to the BM@N setup.

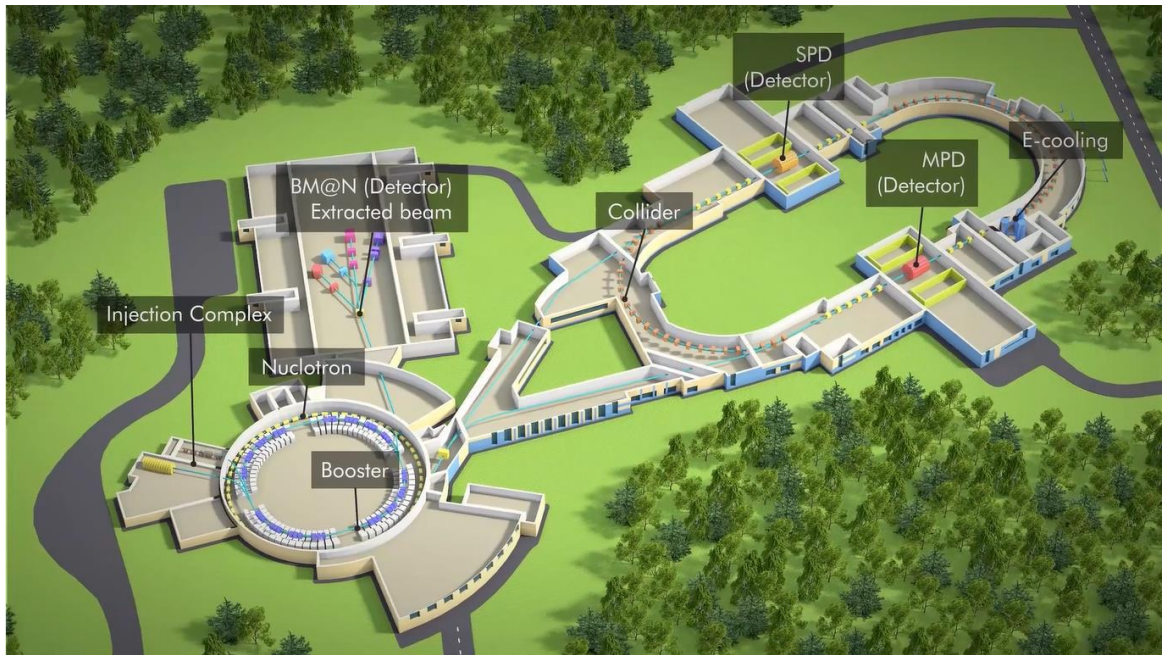

Figure 3.1. Schematic view of the NICA-Nuclotron complex and the position of the BM@N setup.

The planned intensity of the gold ion beam at BM@N is few 10^6 ions/s. The acceleration of the gold ion beam is planned after the Nuclotron upgrade in 2022. In Fig. 3.2 the interaction rates are presented for different experiments with heavy ion collisions at different energies per nucleon-nucleon collision in the center of mass system. The beam energy of the BM@N experiment is in the intermediate range between experiments at the SIS-18 and NICA/FAIR facilities and partially overlaps the energy range of the HADES experiment. The acquisition rate of non-peripheral collisions, i.e., central or intermediate interactions is expected to range from 20 to 50 kHz at the second stage of the BM@N experiment in 2022 and later. The interaction rate is limited by the capacity of the data acquisition system and readout electronics.

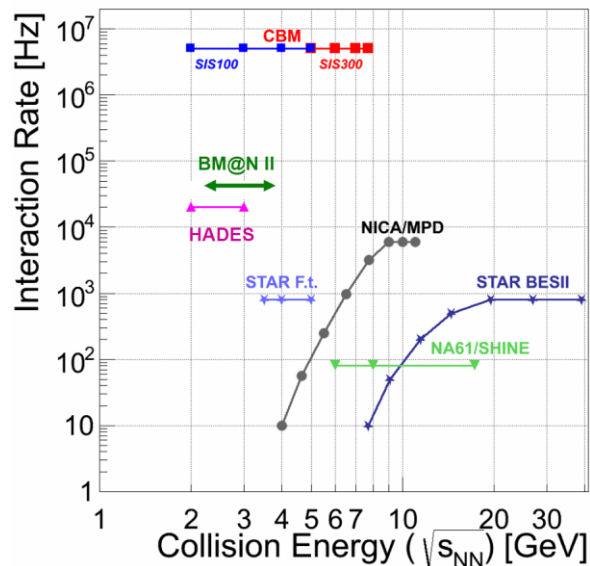

Figure 3.2 Heavy ion experiments: interaction rate and nucleon-nucleon collision energy in c.m.s.

References

[3.1] G. Trubnikov, A. Kovalenko, V. Kekelidze, I. Meshkov, R. Lednicky, A. Sissakian, A. Sorin, PoS (ICHEP 2010) 523.

[3.2] G. Trubnikov, N. Agapov, V. Kekelidze, A. Kovalenko, V. Matveev, I. Meshkov, R. Lednicky, A. Sorin, PoS 36th International Conference of High Energy Physics (ICHEP2012), July 4-11, Melbourne, Australia.

[3.3] V. Kekelidze, A. Kovalenko, R. Lednicky, V. Matveev, I. Meshkov, A. Sorin, G. Trubnikov, 37th International Conference on High Energy Physics, ICHEP 2014, July 2-9, Valencia, Spain, Nuclear physics B Proceedings supplements (2014).

[3.4] V. Kekelidze, Multi-purpose detector (MPD) of the collider experiment, these proceedings.

[3.5] BM@N Conceptual Design Report.

http://nica.jinr.ru/files/BM@N/BMN_CDR.pdf

[3.6] J. Heuser et al., Technical Design Report for the CBM Silicon Tracking System, CBM Collaboration, GSI Report 2013-4,

<http://repository.gsi.de/record/54798>

3.1 Main characteristics of the experimental setup

The layout of the proposed BM@N configuration for heavy ion program is shown in Fig. 3.1.1. The experiment combines high precision measurement of track parameters with time-of-flight information for particle identification and presumes a measurement of the total energy by the hadron calorimeter to analyze the collision centrality. The charged track momentum and multiplicity will be measured using a set of forward silicon detectors (FwdSi), large aperture silicon tracking system (STS), 7 planes of two-coordinate GEM (Gaseous Electron Multiplier) detectors mounted downstream of the target inside of the analyzing magnet. The GEM detectors are operational at high particle densities and in strong magnetic fields. The vertical gap between the poles of the analyzing magnet for detector installation is about 1 m. The magnetic field can reach a maximum value of 1 T, which makes it possible to optimize the BM@N geometrical acceptance and resolution on momentum for different processes and energies of the beam. The outer tracking system will consist of cathode strip chambers which will supplement the existing drift chambers to increase the effectiveness of track measurement in Au+Au collisions. The time-of-flight detectors (ToF) based on the multi-gap Resistive Plate Chamber (mRPC) technologies with strip readout provide an opportunity to separate hadrons (π , K, p) and light nuclei with momentum up to few GeV/c. The Zero Degree Calorimeter (ZDC) detector is foreseen for the extraction of the collision impact parameter (centrality) by measuring the energy of the fragments of colliding particles. The scintillator multiplicity Barrel detector positioned around the target and partially overlapping the backward hemisphere is planned to generate a trigger signal for the data acquisition system. A set of beam trigger detectors will also provide a starting signal (T0) for the time-of-flight detectors.

In 2022, after the heavy ion program upgrade, the BM@N experiment will start with middle size ion (Kr, Xe) beams. At this stage the hybrid central tracker will consist of three two-coordinate planes of the FwdSi detectors and 7 planes of the GEM detectors as it is shown in Fig. 3.1.2. The results of simulations for this configuration of the central tracker are given in section 3.2.2. In 2023 it is planned to add the 4th plane of the FwdSi detectors and two pilot two-coordinate planes of the STS detectors to extend the capacity of the central tracker to run with heavy ion interaction rate up to 20 kHz. The stages of the BM@N experiment from the starting technical runs to the final high intensity runs with heavy ion beams are given in Table 3.1.

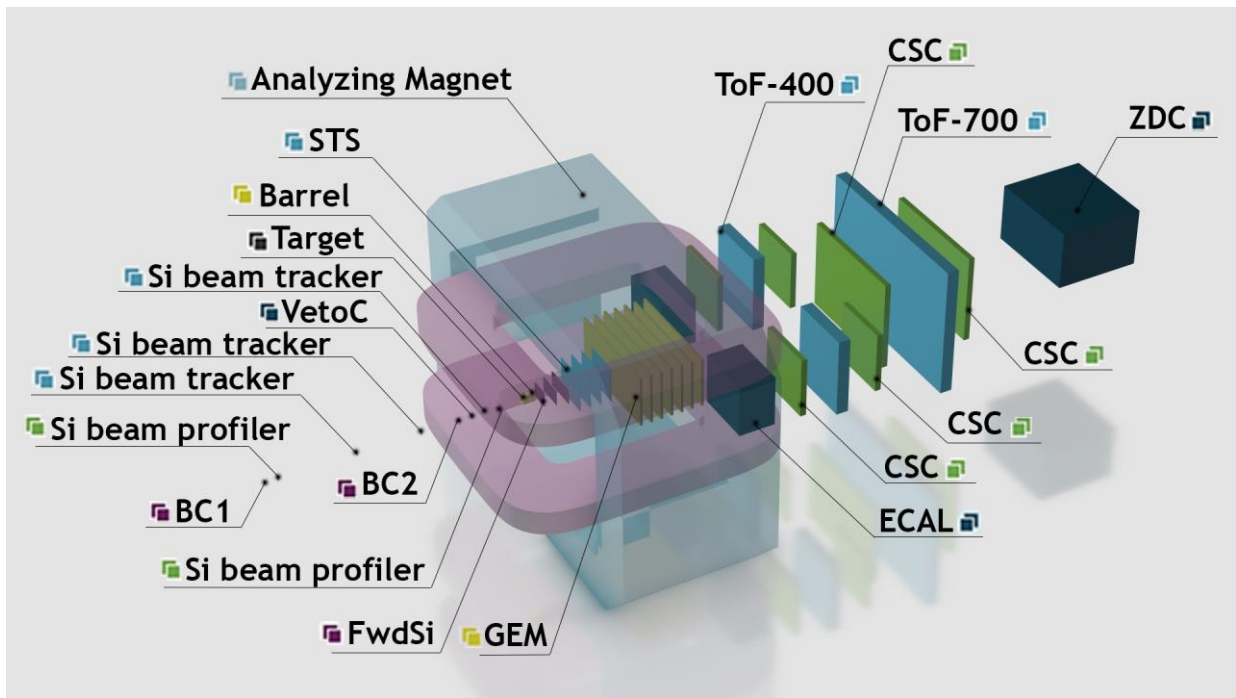

Figure 3.1.1. Schematic view of the BM@N setup for the heavy ion program (without vacuum beam pipe).

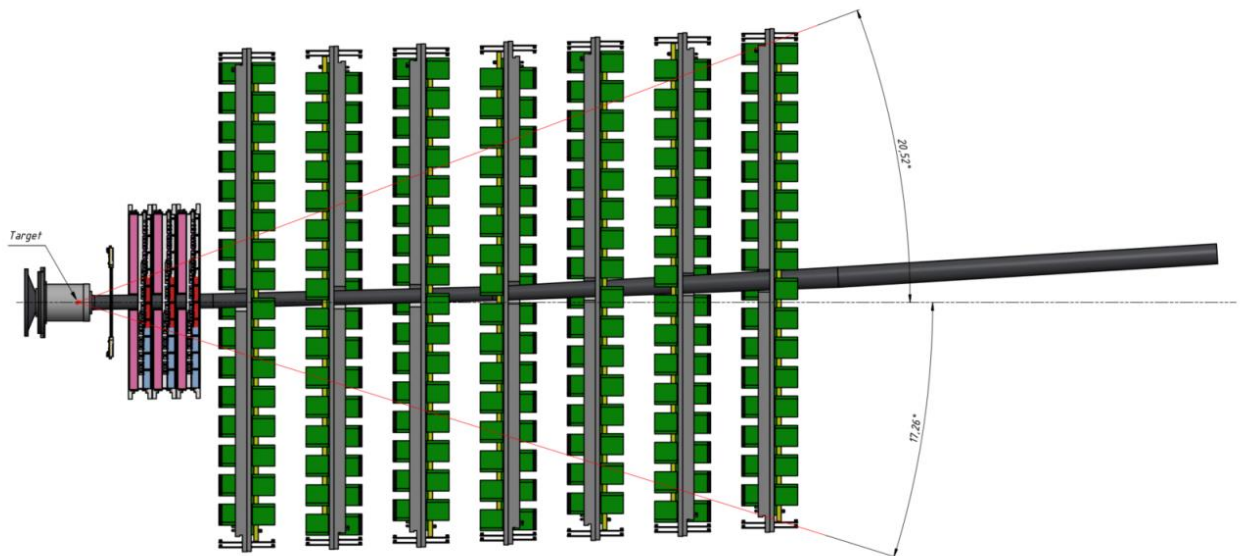

Figure 3.1.2. Schematic view of the initial hybrid tracker based on 3 forward silicon planes and 7 GEM planes. The carbon vacuum beam pipe follows the trajectory of the beam.

At the second stage of the BM@N experiment after 2023, four two-coordinate planes of the STS detectors will be installed in front of the GEM detectors to improve track reconstruction in heavy ion collisions (Fig. 3.1.3). Detectors of this type are currently under development in cooperation with the CBM experiment, therefore the actual implementation of the STS tracker upgrade depends on the timetable of the CBM silicon tracker program. The STS FEE electronics is capable to register interactions with the event rate of 50 kHz, which is the primary goal of the BM@N experiment (see Fig. 3.2). To record interactions with the 50 kHz rate, the FEE electronics of the GEM detectors should be upgraded to a faster version, which is presently under development.

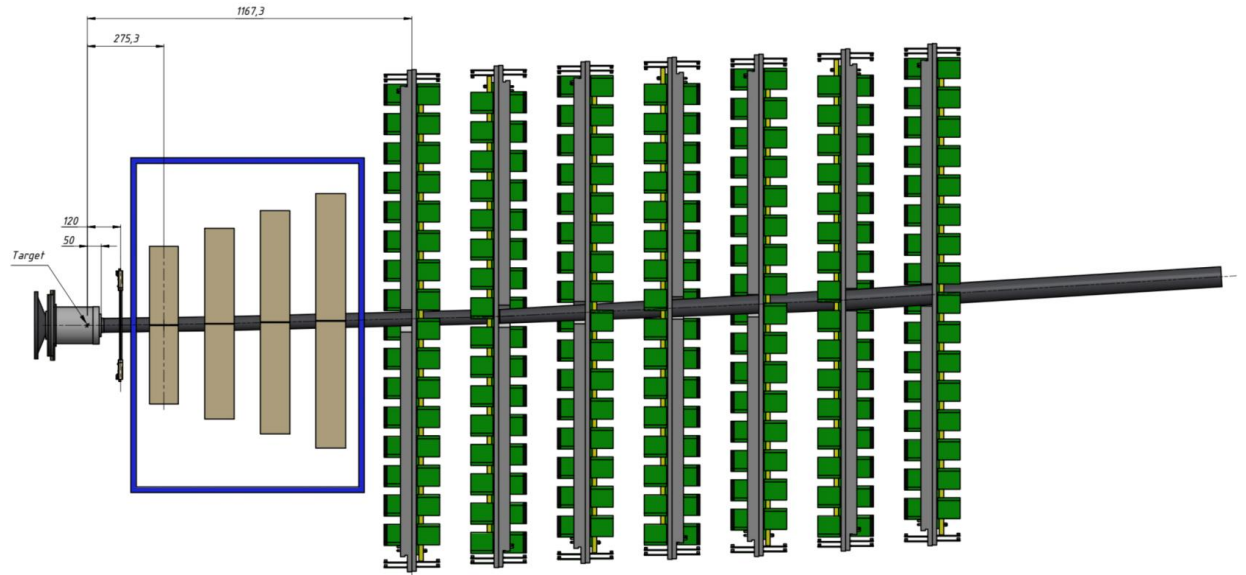

Figure 3.1.3. Schematic view of the final hybrid tracker based on 4 large aperture planes of silicon tracking system and 7 GEM planes.

Table 3.1. Configuration of the BM@N central tracker, beam parameters and event rates in BM@N experimental runs

Year	2016-2017 spring	2018 spring	2022 spring	2023	after 2023
Beam	d, C	Ar,Kr, C(SRC)	Kr,Xe	up to Au	up to Au
Beam intensity, Hz	0.5 M	0.5 M	0.5 M	0.5 M	2 M
Data rate, Hz	5 k	10 k	10 k	20 k	50 k
Central tracker configuration	6 GEM half-planes	6 GEM half-planes + 3 small FwdSi planes	6 GEM full planes + 3 FwdSi full planes	7 GEM planes + 4 FwdSi planes + 2 STS planes	7 GEM planes + 4 STS planes
Status of the experiment	Technical run	Technical run	Physics run, first stage	Physics run	High rate physics run, second stage

3.2 BM@N performance and feasibility study

3.2.1 BM@N performance in the first experimental runs

Technical runs with the BM@N detector were performed in the deuteron beam in December 2016 and in the carbon beam in March 2017. The kinetic energy was 4 GeV/nucleon for the deuteron beam and was varied from 3.5 to 4.5 GeV/nucleon for the carbon beam. The configuration of the BM@N set-up in these runs is shown in Fig.3.2.1.1. The central tracker set-up comprised a forward silicon strip Si plane, five 2-coordinate GEM detectors with the size of 66 x 41 cm² and two GEM detectors with the size of 163 x 45 cm². The GEM detectors were combined into 6 GEM stations. All the GEM detectors are two coordinate detectors and have the strip pitch of 800 μm. The inclination angles of the X and X' coordinates of the GEM detectors to the vertical axis are 0

and 15 degree, respectively. The beam crossed the GEM detectors in the middle of the sensitive planes. The experimental data from the central tracker, outer drift chambers, time-of-flight detectors, zero degree calorimeter and trigger detectors were read out using the integrated data acquisition system.

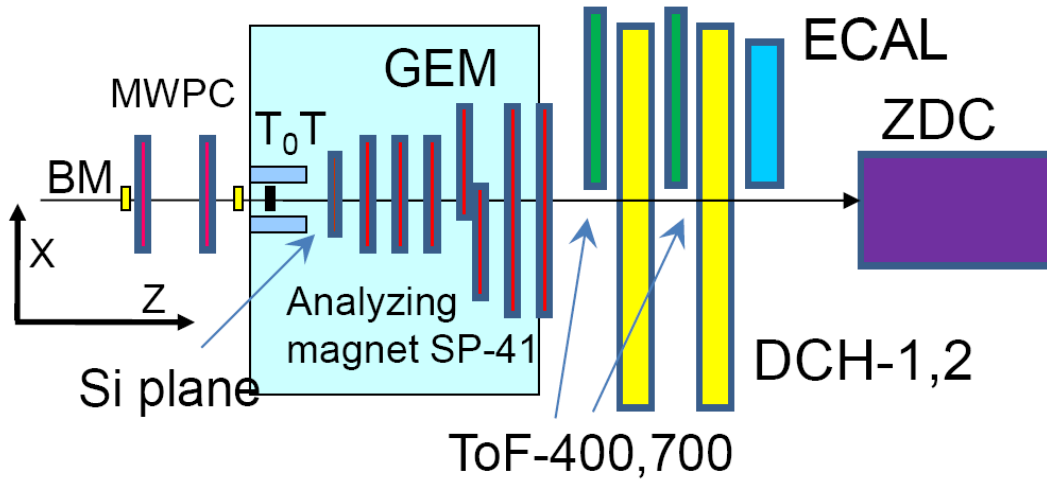

Figure 3.2.1.1 Schematic view of the BM@N setup in the experimental run with the carbon beam.

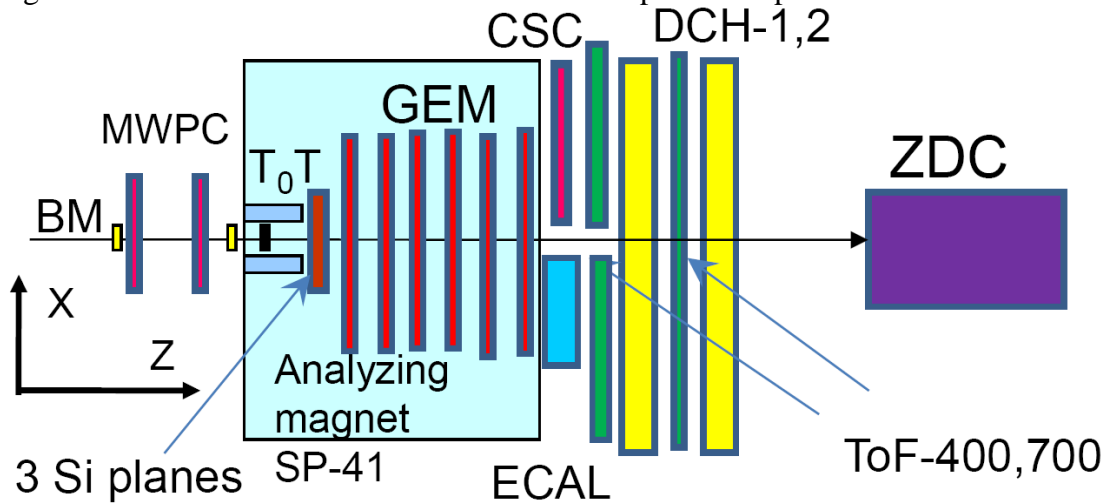

Figure 3.2.1.2 Schematic view of the BM@N setup in the experimental run with the argon and krypton beams.

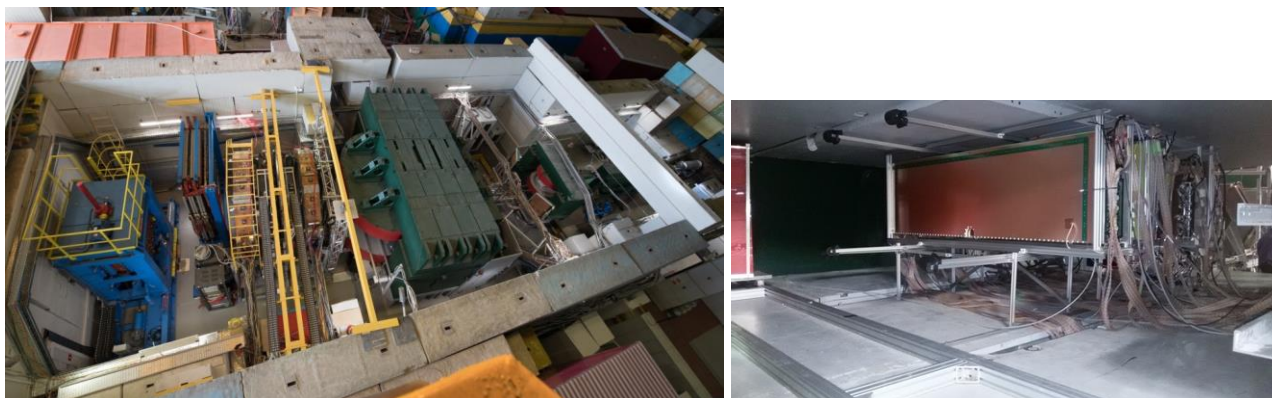

Figure.3.2.1.3 View of the BM@N setup (left plot) and the GEM tracker (right plot) in the experimental run with the argon and krypton beams in March 2018.

The extended configuration of the BM@N set-up was realized in the next runs with the argon and krypton beams performed in March 2018. The schematic view of the set-up is shown in Fig. 3.2.1.2. The photos of the set-up are given in Fig.3.2.1.3. The set-up comprised six 2-coordinate

planes GEM detectors with the size of 163 x 45 cm², three forward silicon strip Si planes, outer tracker based on two drift chambers DCH and a cathode strip chamber CSC, full time-of-flight system consisting of ToF-400 and ToF-700, extended trigger system T₀T, hadron ZDC and electromagnetic ECAL calorimeters. The GEM tracking detectors covered only the upper half of the acceptance within the analyzing magnet. The collected data were used to check efficiencies of sub-detectors and develop algorithms for the event reconstruction and analysis. In particular, experimental data of minimum bias interactions of the beam with different targets were analyzed with the aim to reconstruct tracks, primary and secondary vertices using the central tracking detectors [3.2.8–3.2.11]. The track reconstruction method was based on the so-called ‘cellular automaton’ approach [3.2.13]. Since the GEM tracker configuration in the carbon run was tuned to measure relatively high-momentum beam particles, the geometrical acceptance for relatively soft decay products of strange V₀ particles was rather low. The Monte Carlo simulation showed that only ~4% of Λ hyperons and ~0.8% of K₀s could be reconstructed.

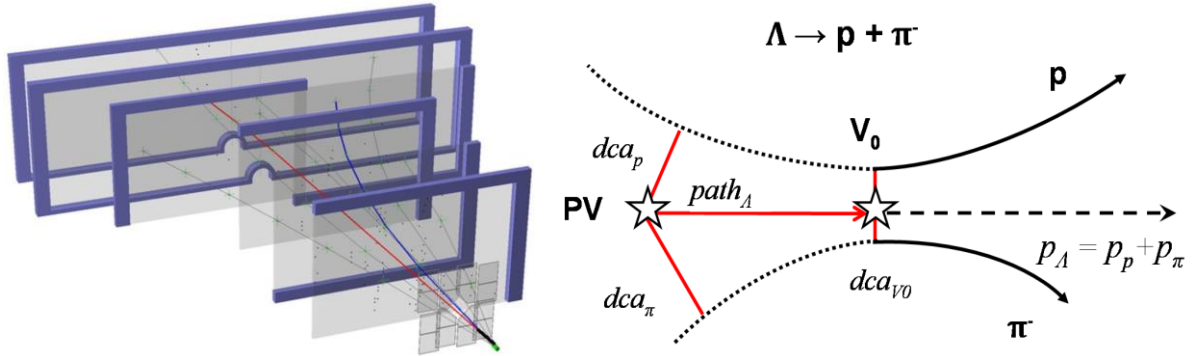

Figure 3.2.1.4 Left plot: Event of Λ hyperon production in a carbon-nucleus interaction reconstructed in the central tracker. Right plot: Topology of $\Lambda \rightarrow p\pi^-$ decay and variables used to select Λ hyperons.

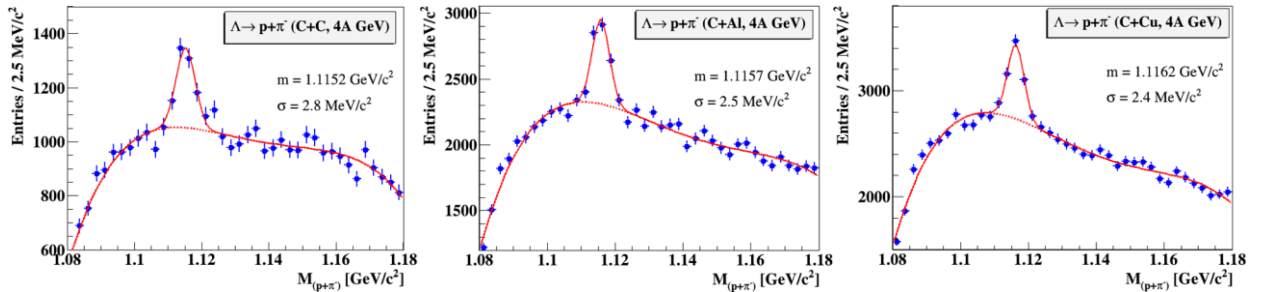

Figure 3.2.1.5 Λ hyperon signals in the invariant mass spectrum of (p, π^-) pairs reconstructed in interactions of the 4 AGeV carbon beam with the C,Al,Cu targets.

Λ hyperons were reconstructed using their decay mode into (p, π^-) pairs as illustrated at Fig.3.2.1.4 [3.2.14]. Since particle identification at this stage of the analysis was not used, all positive tracks were considered as protons and all negative as π^- . The invariant mass distributions of (p, π^-) pairs are shown in Fig. 3.2.1.5 for reconstructed interactions of the carbon beam with the C, Al, Cu targets. The background under the signal will be reduced by introducing additional silicon tracking detectors to improve the primary and decay vertex resolution. The yields of Λ hyperons in minimum bias interactions of the 4 AGeV carbon beam with the C, Al, Cu targets are measured in the kinematic range on the Λ transverse momentum of $0.1 < p_T < 1.05$ GeV/c and the Λ rapidity in c.m.s. of $0.03 < y^* < 0.93$ [3.2.12]. The statistical uncertainties of the measured yields are around 8%, the systematic uncertainties are 9%, 8% and 7%, correspondingly for C+C, C+Al, C+Cu interactions. The y^* and p_T spectra of the Λ hyperon yields corrected for the detector acceptance and efficiency are presented in Fig.3.2.1.6. The error bars represent the statistical uncertainties, the blue boxes show the systematic errors. The predictions of the DCM-QGSM [3.2.15] and UrQMD models are shown for comparison. The measured spectra of the Λ hyperon yields in p_T are parameterized by the form: $1/p_T d^2N/dp_T dy \propto \exp(-(m_T - m_\Lambda)/T)$, where $m_T = \sqrt{(m_\Lambda^2 + p_T^2)}$ is the transverse mass, and the inverse slope parameter T is a free parameter of the fit. The value of T

extracted from the fit of the p_T spectra is about 113 MeV for C+C interactions rising up to 170 MeV for C+Cu interactions. The fit results are consistent within the uncertainties with the model predictions. In general, the considered transport models describe the shape of the differential experimental spectra on y^* and p_T , but differ in the normalization that needs some explanation. The normalization of the DCM-QGSM model prediction for the Λ yield in nucleus-nucleus collisions is dependent on the Λ production cross section in proton-proton interactions that still should be tuned to the recent experimental data. The Λ yield extracted from the UrQMD model is normalized to all nucleus-nucleus interactions generated by the model, including quasi-elastic scattering. The UrQMD prediction for the Λ yield per inelastic nucleus collision is higher by a factor of two and closer to the DCM-QGSM prediction. A smooth rise of the inverse slope parameter of the Λ transverse momentum spectra for heavier target nuclei could be understood within these hadron cascade models as being due to a rising number of multiple interactions producing additional transverse momenta of Λ hyperons in heavier nuclei. The measured yields of Λ hyperons in minimum bias C+C interactions are extrapolated into the full kinematic range using averaged predictions of the DCM-QGSM and UrQMD models. The extrapolation uncertainty derived from the difference of the model predictions is 3.5% which is small in comparison with the 9% systematic uncertainty of the yield measurement. The Λ yield measured by BM@N is compared in Fig.3.2.1.6 with the results of other experiments [3.2.16–3.2.18] and with the model predictions.

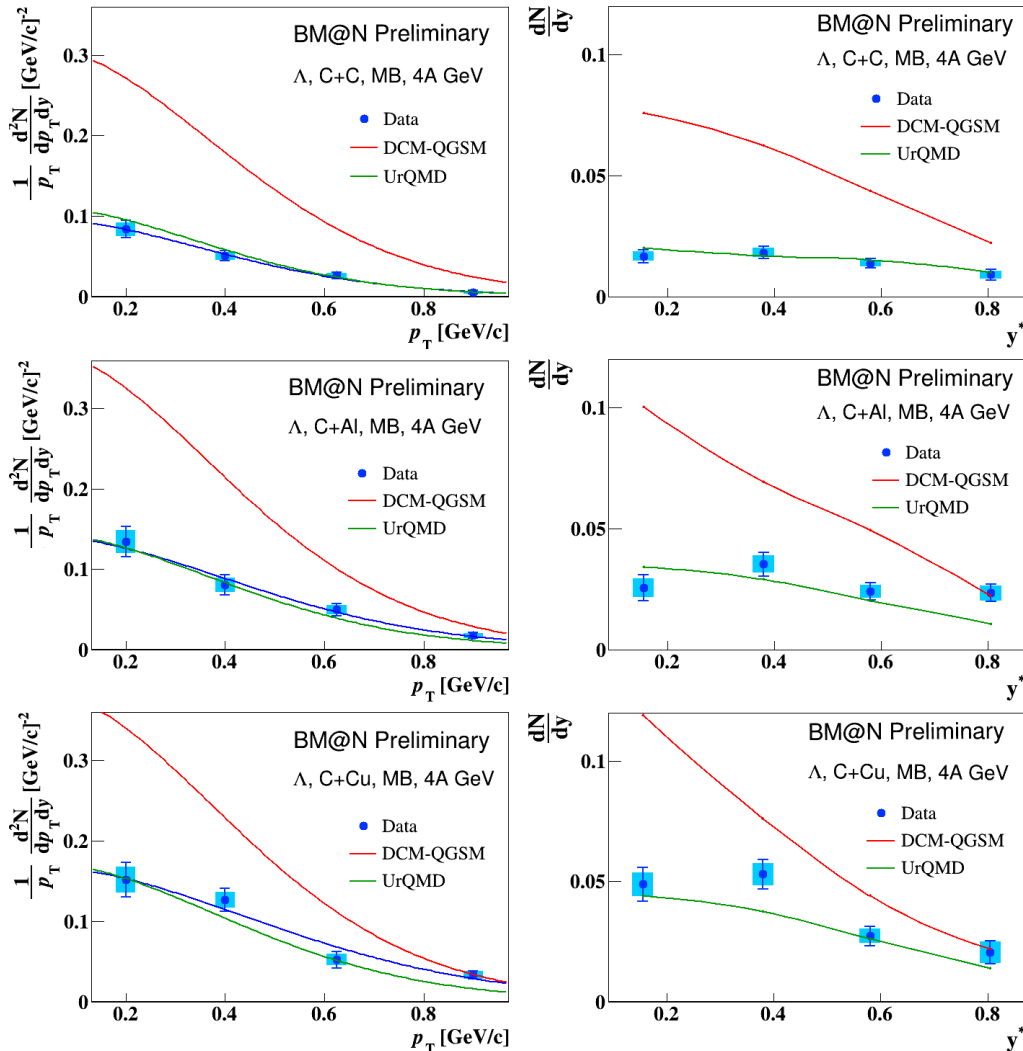

Figure 3.2.1.6 Yields of Λ hyperons in minimum bias C+C, C+Al, C+Cu interactions vs rapidity y^* in c.m.s. (left plots) and transverse momentum p_T (right plots). The error bars represent the statistical uncertainties, the blue boxes show the systematic errors. The predictions of the DCM-QGSM and UrQMD models are shown as colored lines.

A rise of the Λ yield per nucleus collision with the collision energy could be understood within the hadron cascade model as being due to a rising energy available for production of pairs of Λ and kaons in multi-scattering processes in interacting nuclei.

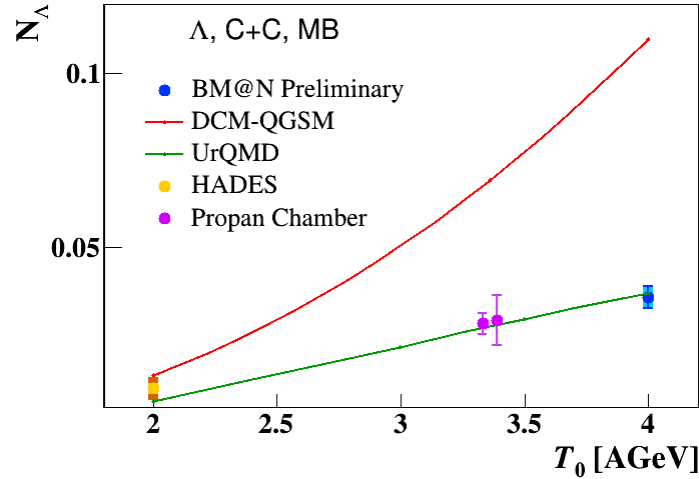

Figure 3.2.1.6 Energy dependence of Λ hyperon yields in C+C interactions. The BM@N result is compared with the data taken from [3.2.16–3.2.18]. The BM@N error bar represents the statistical uncertainty, the blue box shows the systematic error. The predictions of the DCM-QGSM and UrQMD models are shown as colored lines.

In analogy with the analysis of the carbon beam data, Λ hyperons were reconstructed in argon-nucleus interactions using their decay mode into (p, π^-) pairs. Candidates to Λ decays were reconstructed as neutral V^0 topologies without identification of the decay products as it is shown in Fig.3.2.1.7(left). All positive tracks were considered as protons and all negative tracks as π^- . The invariant mass distribution of (p, π^-) pairs is shown in Fig. 3.2.1.7(right) for reconstructed interactions of the argon beam with fixed targets. The Λ hyperon signal has a width sigma of 3-3.5 MeV for different targets, which is similar to the width of the Λ signal in carbon-nucleus interactions. Taking into account the momentum spectra of reconstructed p, π^- decay products, the 3-3.5 MeV Λ mass resolution corresponds to 2.5-3.5% momentum resolution for p, π^- .

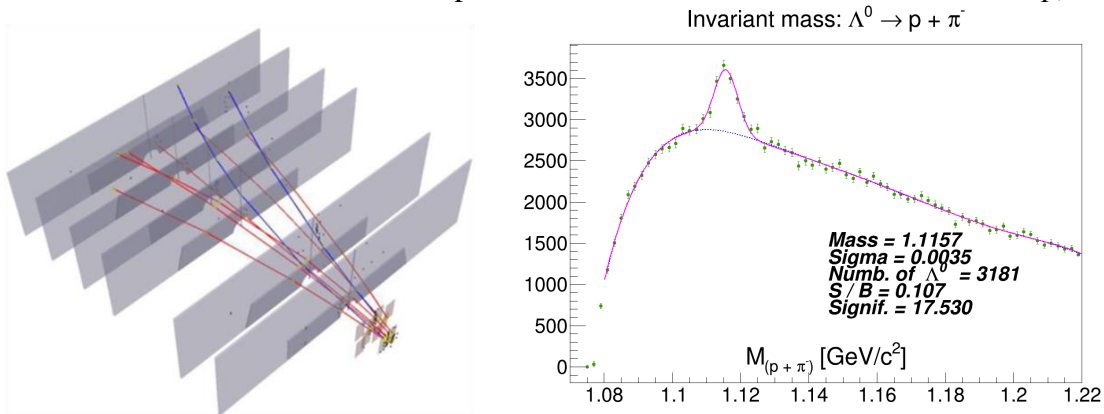

Figure 3.2.1.7 Left plot: Event of Λ hyperon production in a argon-nucleus interaction reconstructed in the central tracker. Right plot: Λ hyperon signal in the invariant mass spectrum of (p, π^-) pairs reconstructed in interactions of the 3.2 AGeV argon beam with the fixed targets.

Charged kaons and pions, as well as protons and light nuclear fragments, were identified in the experimental data obtained in interactions of the 3.2 AGeV argon ion beam with fixed targets (C,Al,Cu,Sn,Pb) using the central tracking system (measuring the particle momentum and trajectory in the coordinate silicon detectors and GEM detectors) and the time-of-flight system of ToF-400 and ToF-700 based on the mRPC detectors (chambers) measuring the time of flight of charged particles from the starting T0 detector to the mRPC chambers. The particle velocity is determined from the length of the particle trajectory from the target to the mRPC chambers and the time of flight. Knowing the momentum and velocity of particles allows us to determine the mass

and identify the particle. To improve reconstruction of the particle momentum, the detector alignment was performed, i.e. the positions and rotations of the silicon coordinate detectors and GEM detectors were determined by software methods. To improve the time-of-flight measurement the response of the time-of-flight detectors T0 and mRPC was calibrated: the raw time-of-flight was corrected for the channel-by-channel time offset, for the propagation time in the MRPC strip, and for the correlation of the time measurement with the signal amplitude. The final tuning of the time-of-flight for individual mRPC chambers was performed using a large statistical sample of identified protons: the mean time-of-flight measured in a chamber was adjusted to put the mean value of the mass of particles identified in the chamber as protons to the tabular value of the proton mass. The achieved time resolution of the ToF-400 and ToF-700 systems was 85 ps and 120 ps, respectively.

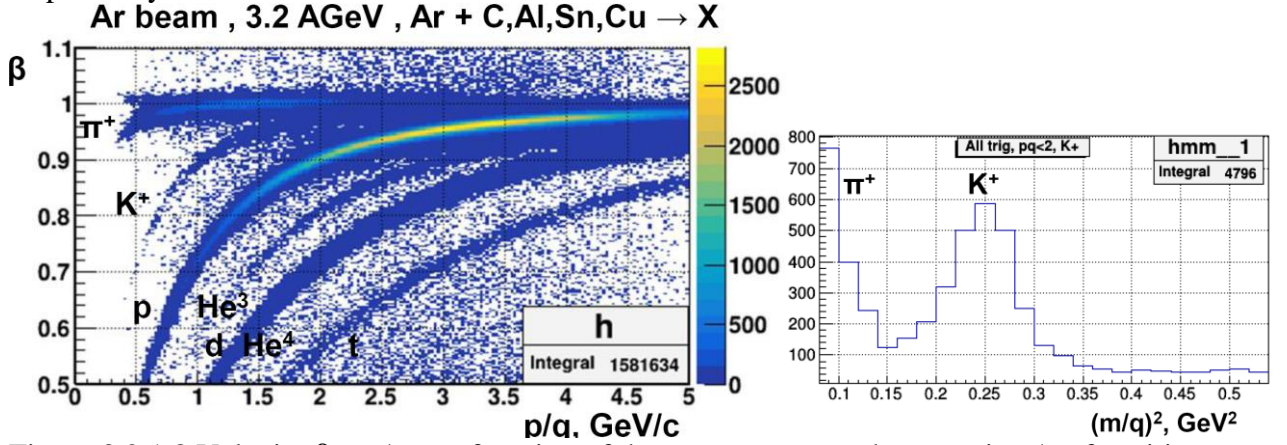

Figure 3.2.1.8 Velocity $\beta = v/c$ as a function of the momentum-to-charge ratio p/q of positive charged particles measured in the ToF-400 system. Identified π^+ , K^+ , p , He^3 , d/He^4 , t are visible as populated bands of particles (left plot). Distribution of the squared mass-to-charge ratio of identified particles showing peaks of π^+ and K^+ (right plot).

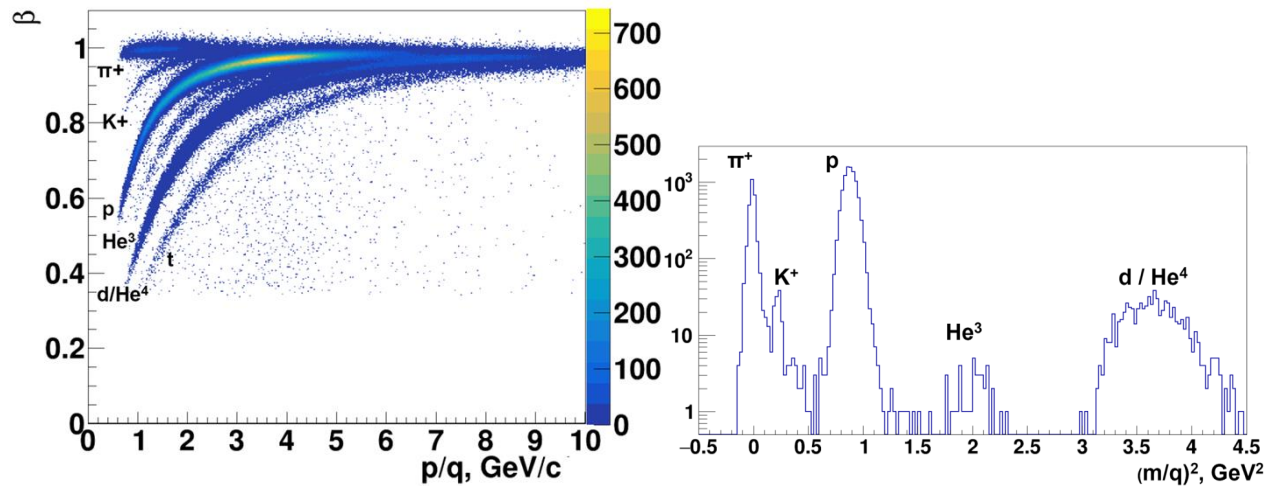

Figure 3.2.1.9 Velocity $\beta = v/c$ as a function of the momentum-to-charge ratio p/q of positive charged particles measured in ToF-700 system. Identified π^+ , K^+ , p , He^3 , d/He^4 , t are visible as populated bands of particles (left plot). Distribution of the squared mass-to-charge ratio of identified particles showing the π^+ , K^+ , p peaks and light fragments (right plot).

The coordinate resolution of the mRPC detectors along the readout strips is 0.75 cm. Within the framework of the project, response of the time-of-flight detectors was simulated, and an algorithm for identifying particles in multiparticle events was developed. The results of particle identification in the ToF-400 and ToF-700 detectors are shown in Fig. 3.2.1.8 and Fig. 3.2.1.9, respectively. The populated bands of particles at the left plots and the peaks in the mass distributions at the right plots correspond to identified π^+ , K^+ , p , He^3 , d/He^4 , t . In particular, the distributions of the squared mass-to-charge ratio of identified particles show the π^+ peak at low values of $(M/q)^2$ and the K^+ peak at ~ 0.25 GeV² (right plots). The analysis is going on to correct the identified data for the

detector acceptance and efficiencies and extract the yields of π^\pm , K^\pm mesons, Λ hyperons and light nuclear fragments in argon-nucleus interactions.

3.2.2 Simulation of the central tracker for the heavy ion program

The layout of the upgraded BM@N configuration for heavy ion program is shown in Fig. 3.1.1. At the first stage of the experiment starting in 2022, three planes of the forward silicon detectors will be used in combination with seven stations of the GEM detectors to reconstruct interactions of middle size ions (Kr,Xe) with fixed targets (Fig.3.1.2). After 2023, at the final stage of the experiment, four planes of the large aperture two-coordinate silicon tracking system STS will be installed in front of the GEM detectors (Fig.3.1.3) to improve track reconstruction in heavy ion collisions.

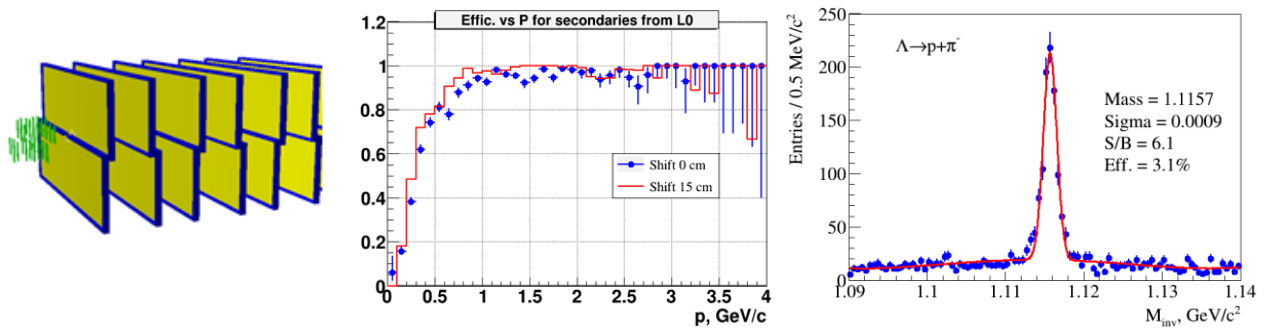

Figure 3.2.2.1 Left plot: Simulated configuration of the first stage of the hybrid tracker based on 3 FwdSi planes and 7 GEM detector planes. Central plot: Efficiency of the Λ decay product (proton or π^-) reconstruction in the hybrid FwdSi+GEM tracker in simulated Kr+Pb interactions. Right plot: Signal of Λ hyperon in the invariant mass spectrum of simulated (p, π^-) reconstructed in the hybrid FwdSi+GEM tracker.

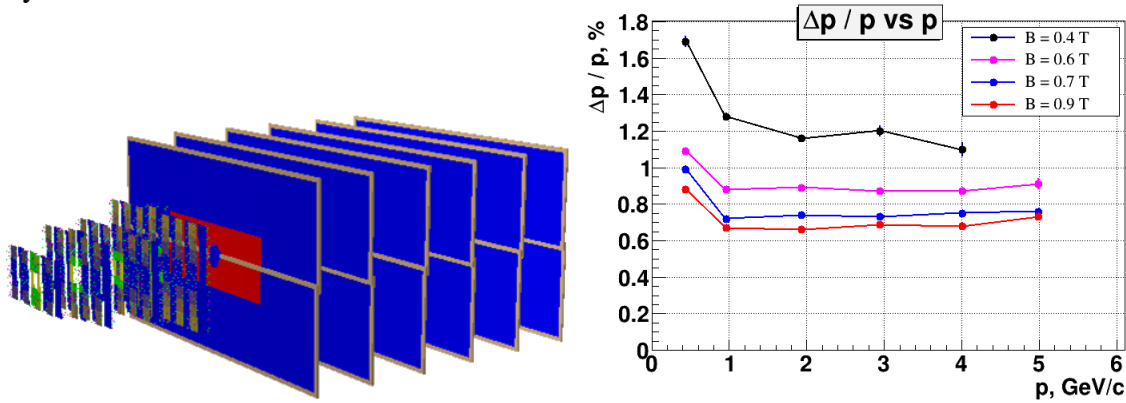

Figure 3.2.2.2 Left plot: Simulated configuration of the final stage of the hybrid tracker based on 4 STS stations and 7 GEM detector planes. Right plot: Momentum resolution of the hybrid tracker as a function of the particle momentum calculated for different values of the magnetic field.

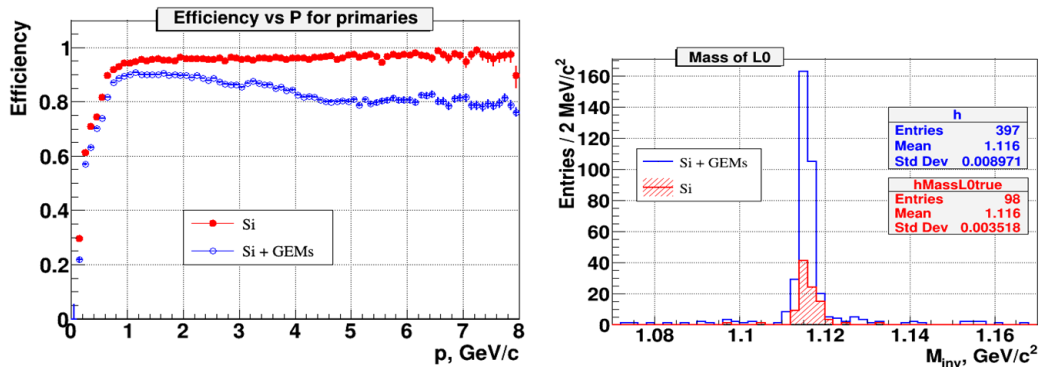

Figure 3.2.2.3 Left plot: Efficiency of primary charge particle reconstruction in the hybrid STS+GEM tracker (blue histogram) and STS tracker alone (red histogram). Right plot: Reconstructed signal of Λ hyperon for the STS and STS+GEM tracker configurations.

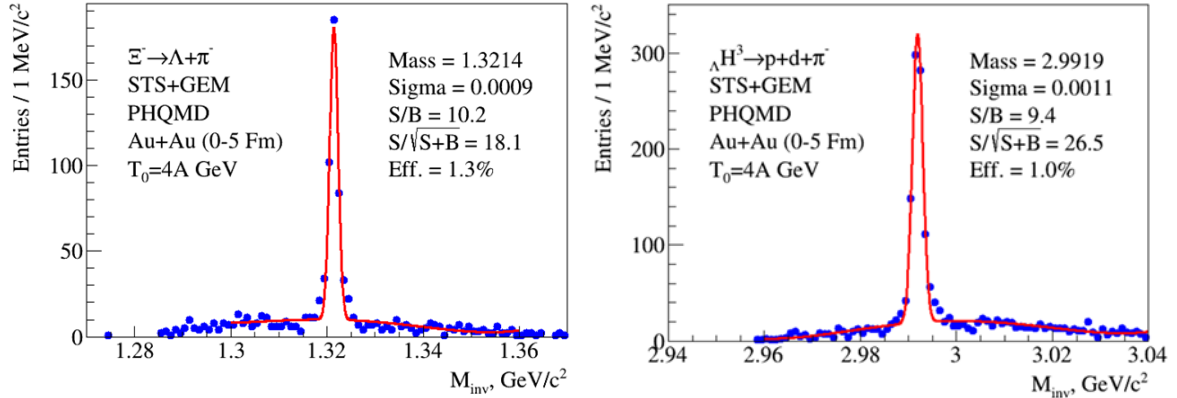

Figure 3.2.2.4 Left plot: Signal of Ξ^- hyperon in the invariant mass spectrum of simulated (Λ , π^-) reconstructed in the hybrid STS+GEM tracker. Right plot: Signal of ΛH^3 in the invariant mass spectrum of simulated (p , d , π^-) reconstructed in the hybrid STS+GEM tracker.

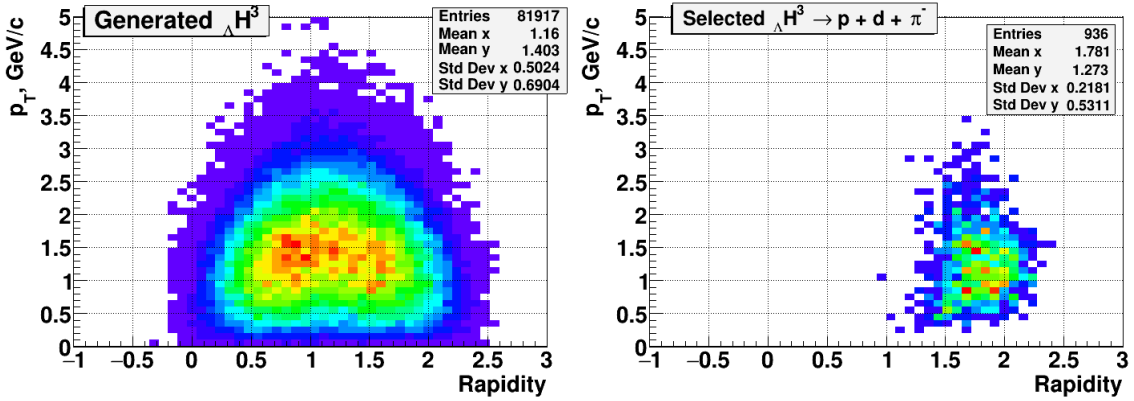

Figure 3.2.2.5 Left plot: distribution of ΛH^3 generated in Au+Au collisions at the beam kinetic energy of 4 AGeV in the phase space of the ΛH^3 transverse momentum and rapidity in the laboratory frame. Right plot: distribution of reconstructed ΛH^3 as a function of the ΛH^3 transverse momentum and rapidity.

The simulated configuration of the 1st stage of the hybrid tracker based on 3 forward silicon stations and 7 GEM detector planes (Fig.3.1.2) is shown in Fig. 3.2.2.1(left). The efficiency of the $\Lambda \rightarrow p + \pi^-$ decay product reconstruction in the hybrid FwdSi+GEM tracker in simulated interactions of the Kr beam with the Pb target is shown in Fig. 3.2.2.1(right). Results for two positions of the FwdSi detectors are presented: default (Shift 0 cm) and shifted additionally at +15 cm from the interaction point. Within the framework of the BM@N upgrade [3.2.20], the final central tracking system based on the large aperture STS and GEM detectors (Fig. 3.1.3) was simulated to study its performance for reconstruction of hyperons and hypernuclei in interactions of heavy nuclei (up to Au+Au). As it is mentioned above, studies of Au+Au interactions are planned at the final stage of the BM@N experiment with heavy ion beams. The efficiency of reconstruction of primary charged particles in simulated central Au+Au collisions is presented in Fig. 3.2.2.2(central) for the hybrid STS+GEM tracking system (blue histogram) and for the silicon STS stations alone (red histogram). Although the GEM detectors are less efficient in high multiplicity events due to lower granularity than the STS detectors, the STS+GEM tracking algorithm is able to reconstruct four times more Λ hyperons than that of the STS tracker alone. The momentum resolution of the hybrid tracker is shown in Fig. 3.2.2.2(right). The hybrid tracking system is also able to reconstruct cascade decays of Ξ^- hyperons to $\Lambda + \pi^-$ and hypertriton nuclei ΛH^3 in the decay modes to $He^3 + \pi^-$ and $p + d + \pi^-$ with a similar efficiency. The Ξ^- and ΛH^3 signals reconstructed in the

STS+GEM tracking system are shown in Fig. 3.2.2.4. To reconstruct events with the Ξ^- or Λ^3 decay topologies the algorithm developed at CBM [3.2.21] was used and the selection criteria were applied on the distance of the closest approach to the primary vertex of decay products, distance between tracks in the decay vertex, path length of the reconstructed mother particle. In addition, to reduce the combinatorial background under the Λ^3 signal in the decay modes to $\text{He}^3 + \pi^-$ and $p + d + \pi^-$, the identification of He^3 and d was required in the ToF system. More details of the upgraded setup simulation could be found in [3.2.22]. The distribution of Λ^3 generated in Au+Au collisions at the beam kinetic energy of 4 AGeV in the phase space of the Λ^3 transverse momentum and rapidity in the laboratory frame and distribution of reconstructed Λ^3 as a function of the Λ^3 transverse momentum and rapidity are shown in Fig.3.2.2.5.

Expected statistics of hyperons to be collected per second and for a quartal of data taking is given in the last two columns of the table below. We foresee 3-4 months of data taking per year.

Particle	$E_{\text{thr,NN}}$ GeV	M central	M m.bias	ϵ %	Yield/sec m. bias	Yield/quartal m. Bias
Ξ^-	3.7	$1 \cdot 10^{-1}$	$2.5 \cdot 10^{-2}$	1	2.5	$5 \cdot 10^6$
Ω^-	6.9	$2 \cdot 10^{-3}$	$5 \cdot 10^{-4}$	1	$5 \cdot 10^{-2}$	$1 \cdot 10^5$
Anti- Λ	7.1	$2 \cdot 10^{-4}$	$5 \cdot 10^{-5}$	3	$1.5 \cdot 10^{-2}$	$3 \cdot 10^4$
Ξ^+	9.0	$6 \cdot 10^{-5}$	$1.5 \cdot 10^{-5}$	1	$1.5 \cdot 10^{-3}$	$3 \cdot 10^3$
Ω^+	12.7	$1 \cdot 10^{-5}$	$2.5 \cdot 10^{-6}$	1	$2.5 \cdot 10^{-4}$	$5 \cdot 10^2$

In the table M(central) and M (m.bias) are the yields of hyperons per central / min bias event in Au+Au interactions at the kinetic beam energy of 4 AGeV predicted by the statistical model [2.17], ϵ is the estimated hyperon reconstruction efficiency, $E_{\text{thr,NN}}$ is the kinematical threshold for the hyperon production. The DAQ event rate is assumed 10^4 Hz and the accelerator duty factor is taken as 0.25. Taking the statistical model predictions for hypernuclei yields per event and 1% reconstruction efficiency, the expected yields of hypernuclei Λ^3 and $\Lambda\Lambda^5$ for a quartal of data taking are 10^6 and 100, respectively.

References

- [3.2.1] J. Steinheimer et al., Progress in Particle and Nuclear Physics 62, 313317 (2009).
- [3.2.2] J. Steinheimer, K. Gudima, A. Botvina, I. Mishustin, M. Bleicher, H. Stoecker, Phys. Lett. B 714, 85 (2012).
- [3.2.3] NICA White Paper.
<http://theor0.jinr.ru/twiki-cgi/view/NICA/NICAWhitePaper>
- [3.2.4] BM@N Conceptual Design Report:
http://nica.jinr.ru/files/BM@N/BMN_CDR.pdf
- [3.2.5] D. Suvarieva et al., J.Phys.Conf.Ser. 668 (2016) no.1, 012121.
- [3.2.6] V. Friese, Strangeness Prospects with the CBM Experiment, talk at the SQM-2015 Conference, Dubna, Russia, July 6-11, 2015.
- [3.2.7] D. Baranov et al., JINST 12 (2017) no.06, C06041.
- [3.2.8] M. Kapishin (for the BM@N Collaboration), Eur.Phys.J. A52 (2016) no.8, 213.

- [3.2.9] M. Kapishin (for the BM@N Collaboration), Phys.Atom.Nucl. 80 (2017) no.10, 1613-1619, Yad.Fiz. 7 (2016) no.6, 543-550.
- [3.2.10] M. Kapishin (for the BM@N Collaboration), Nucl.Phys. A982 (2019) 967-970.
- [3.2.11] M. Kapishin, Proceedings of the 13th International Conference on Nucleus-Nucleus Collisions (NN 2018), JPS Conference Proceedings, v.32 (2020), 010093
- [3.2.12] M. Kapishin (for the BM@N Collaboration), The XVIII International Conference on Strangeness in Quark Matter (SQM 2019), Springer Proceedings in Physics, v.250 (2020), 21-27
- [3.2.13] V. Akishina and I. Kisel, J. Phys.: Conf. Ser. 599, 012024 (2015), I. Kisel, Nucl. Instrum. Meth. A 566, 85 (2006).
- [3.2.14] D. Baranov et al., Phys.Part.Nucl.Lett. 15 (2018) no.2, 148-156.
- [3.2.15] N. Amelin, K. Gudima, and V. Toneev, Sov.J.Nucl. Phys. 51, 1093 (1990).
- [3.2.16] S. Arakelian et al., P1-83-354, JINR, Dubna.
- [3.2.17] D. Armutlijsky et al., P1-85-220, JINR, Dubna.
- [3.2.18] K. Kanaki, Study of hyperon production in C+C collisions at 2A GeV beam energy with the HADES spectrometer, PhD 2007.
- [3.2.19] F. Guber et al., Measurement of centrality in nucleus-nucleus collisions at the BM@N experiment, these proceedings.
- [3.2.20] P. Senger, D. Dementev, J. Heuser, M. Kapishin, E. Lavrik, Yu. Murin, A. Maksymchuk, H.R. Schmidt, Ch. Schmidt, A. Senger and A. Zinchenko, Upgrading the Baryonic Matter at the Nuclotron Experiment at NICA for Studies of Dense Nuclear Matter, Particles, 2, 481 (2019).
- [3.2.21] S. Gorbunov and I. Kisel, Reconstruction of decayed particles based on the Kalman filter, CBM-SOFT-note-2007-003 (2007).
- [3.2.22] A. Zinchenko et al., Performance evaluation of the upgraded BM@N setup for the strangeness production studies, these Proceedings

3.3 Central tracker

3.3.1 GEM tracker

Central tracking system of the BM@N experiment will provide precise momentum measurements of the cascade decays products of multi-strange hyperons and hyper-nuclei produced in central Au-Au collisions. All physics measurements will be performed in conditions of high beam intensities in collisions with large multiplicity of charged particles. This requires the use of detectors with the capacity to resolve multiple tracks produced at very high rate. The basic requirements for the tracking system are: capability of stable operation in conditions of high radiation loadings up to 10^5 Hz/cm², high spatial and momentum resolution, geometrical efficiency better than 95%, maximum possible geometrical acceptance within the BM@N experiment dimension, operation at a 0.8 T magnetic field. Detectors based on the GEM technology possess all the mentioned characteristics combined with the capability of stable operation in a strong magnetic field up to 1.5T. Detectors of this kind are already widely used in such experiments as TOTEM, COMPASS, BNL and are planned for the CMS Muon Endcap upgrade.

BM@N GEM detectors.

Production and assembly processes of the large size (up to 2m long) GEM-based detectors are well developed at CERN PH DT and MPT Workshop. Since non-glue «foil-stretching» technology is involved, one chamber can be assembled in several hours and easily re-opened for technical service if needed. For this reason, two coordinate triple GEM detectors were chosen for the central part of the BM@N tracking system. Triple-GEM configuration performs low probability of discharge propagation and stable operation at gains above 10^5 . BM@N GEM detectors consist of three multipliers, with a drift gap of 3 mm, first transfer gap of 2.5 mm, second transfer gap of 2 mm and an induction gap of 1.5 mm. Two-coordinate readout of the signal is done by the sets of parallel

metal strips on the anode readout board. The inclination angles of bottom layer strips (X coordinate) and top layer strips (X' (or Y) coordinate) to the vertical are 0 and 15 degree, respectively. X and X' strip widths are 0.68 and 0.16 μm . The strip pitch is 800 μm for both layers. Groups of 128 strips are connected to the inputs of the front-end ASIC via a connector on the readout board. The transverse structure of the triple GEM detector and readout board design are shown in figure 3.3.1.

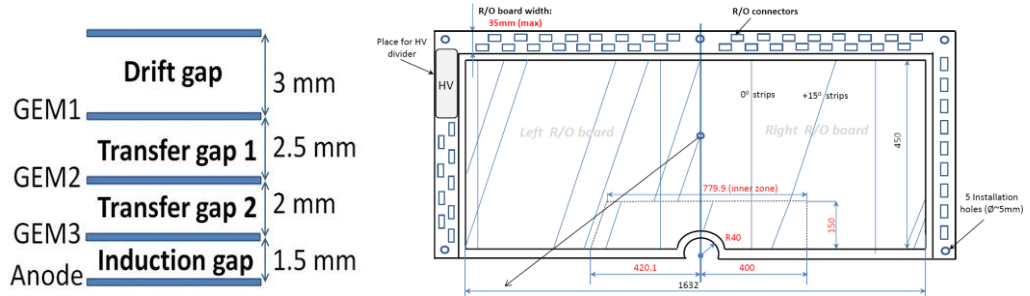

Figure 3.3.1. Left plot: Schematic transverse structure of the triple GEM detector. Right plot: Two-coordinate readout board of the $1632 \times 450 \text{ mm}^2$ GEM detector.

The BM@N GEM tracking system final configuration will consist of two types of the GEM chambers: $1632 \times 450 \text{ mm}^2$ and $1632 \times 390 \text{ mm}^2$. In order not to be flooded by the primary non-interacting heavy ion beam particles and near halo there is a hole in the central region of the detector. Because of large multiplicity near the beam line, readout layer is divided into outer and inner (hot) zones for both types of detectors.



Figure 3.3.2. Left plot: GEM chambers integrated into BM@N experimental setup. Right plot: Cosmic ray test bench.

Beam tests of seven $1632 \times 450 \text{ mm}^2$ GEM chambers equipped with VA163 based FEE were performed in 2018 with the argon and krypton beams (Fig. 3.3.2, left plot). The GEM detectors were filled with the flowed Ar(80)/C₄H₁₀(20) gas mixture to increase the avalanche electrons velocity. The tracks of charged particles were reconstructed and track detection efficiency of the GEM chambers was calculated (estimated average efficiency $\sim 95\%$). Gaussian fit of hit residuals distribution gives standard deviation of 230 μm . Seven $1632 \times 390 \text{ mm}^2$ GEM detectors have been assembled in 2019. Now the detectors equipped with electronics are under long-term measurements with cosmic rays (Fig. 3.3.2, right plot). Performance of the GEM detectors in the technical run with the deuteron beam is illustrated in Fig.3.3.2.1-3.3.2.3.

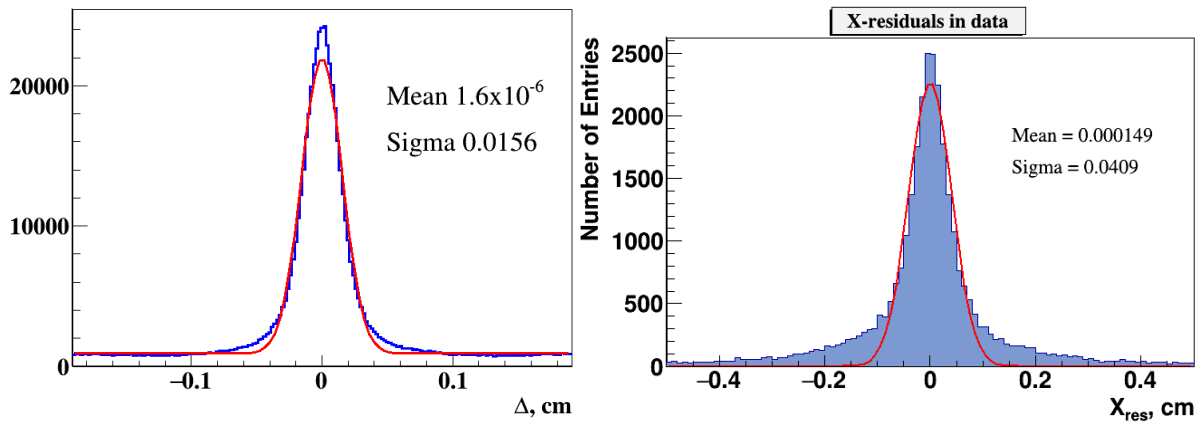

Fig.3.3.2.1 GEM hit to track residuals measured in beam-target interactions without magnetic field (left) and with magnetic field On (right).

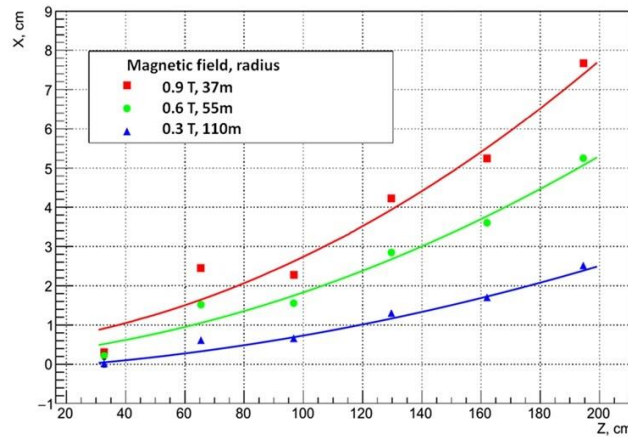

Fig. 3.3.2.2 Average trajectories of the deuteron beam and the average Lorentz shifts of an electron avalanche in 6 GEM planes measured for three values of the magnetic field.

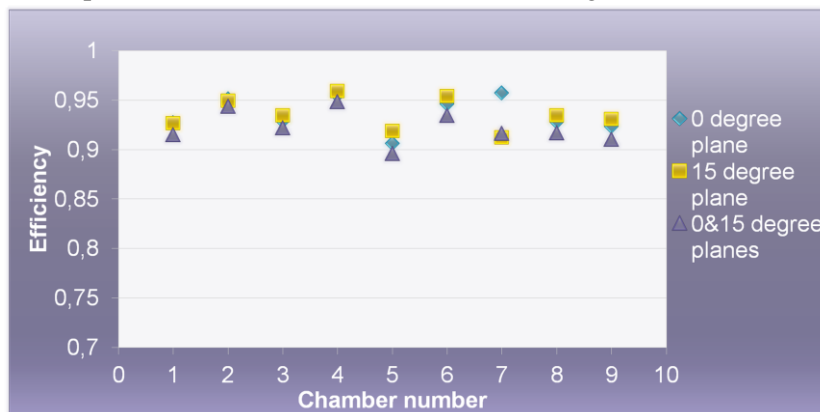

Fig. 3.3.2.3 GEM chamber efficiencies measured in the deuteron beam run.

Front-end electronics and DAQ system

For heavy ion program with the beam intensities up to few 10^5 Hz GEM front-end electronics is based on the charge sensitive pre-amplifier chip VA163 (IDEAS, Norway). The chip has 32 channels. Each channel contains a charge-sensitive preamplifier, a shaper with $2 \mu\text{s}$ (VA-162 chip) and $0.5 \mu\text{s}$ (VA-163 chip) peaking time and a sample-hold circuit. An analog multiplexer with 32 inputs allows one to perform serial read-out channel by channel. The chip can be used to amplify and read negative and positive charges in the range from -1.5 pC to $+1.5 \text{ pC}$. The equivalent noise charge is 1900e without load, and 2000e at 50 pF input load. The integral linearity is 1% and 3% for positive and negative charge, respectively. Each read out card includes four chips, which are

installed, bonded and filled with black compound. Thus, we have 128 input analog channels read-out board (Fig. 3.3.3).

The multiplexed data from each board are transmitted through 15 m of twisted pair flat cable to the 12-bit analog-to-digital converter (ADC) readout by the BM@N data acquisition system.



Fig. 3.3.3. 128 channel read-out board based on VA163 chip. Front and back side view.

For heavy ion program with the beam intensities up to few 10^6 Hz GEM electronics is to be upgraded. VMM3a and TIGER ASICs are considered as possible candidates. First tests of FEE based on both chips are already started. For VMM3a tests with BM@N GEM detectors Kintex7 based 128-channel evaluation board was designed and produced (see Fig. 3.3.4). Before 2023 new electronics will be integrated into the BM@N experimental setup.

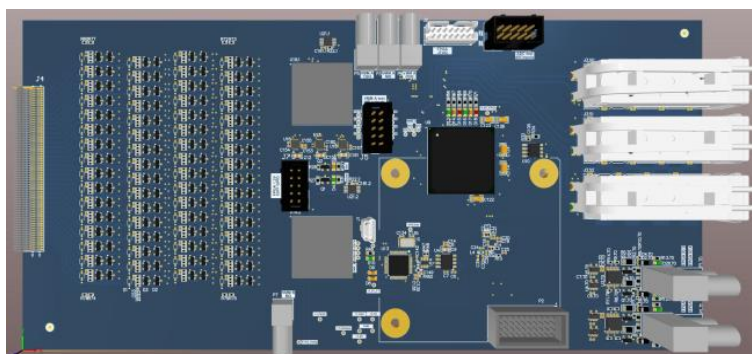

Fig. 3.3.4. Kintex7 based 128-channel GEM evaluation board for VMM3a tests

Gas distribution system

GEM chambers can be operated with Ar(70)/CO₂(30), Ar(90)/C₄H₁₀(10), Ar(80)/C₄H₁₀(20) gas mixtures. The gas system consists of two parts: 1) the mixer system which delivers quantity, mixing ratio and pressure conditioning to downstream elements; 2) the distribution system, which delivers the gas in well defined quantities to the individual detectors. The gas system is produced by Ltd «Eltochpribor» (Zelenograd, Russia). To reduce oxygen and moisture impurities in GEM gas mixture, it will be distributed to detectors by seven independent gas lines, one for each GEM plane. Gas panel designed to control oxygen and moisture impurities in gas mixture is currently under development and will be based on GE oxy.IQ analyzers.

High voltage and low voltage supply systems

Seven needed potentials are distributed to the GEM chamber through the HV divider. Such scheme of HV supply is very convenient, as only one channel of HV power supply is needed to power the chamber via a single cable. Thus, to power final GEM setup of 14 GEM chambers with the voltage of approximately -3kV, a 14-channel high-voltage system is required. For GEM HV power system two 12 channel CAEN AG550DN modules in CAEN SY5527lc_p create are used.

The LV power system is based on four NTN 350-6,5 and six NTN 700-6,5 LV modules. NTN low voltage module has adapter for remote control via Ethernet connection. It is possible to use Ethernet control to integrate the low voltage source to the BM@N Slow Control System database.

Integration into the BM@N setup

The final configuration of the central tracking system consists of 14 GEM detectors:

- 7 GEM detectors of the size $1632 \times 450 \text{ mm}^2$ – above the vacuum beam pipe;
- 7 GEM detectors of the size $1632 \times 390 \text{ mm}^2$ – below the vacuum beam pipe.

Since the magnetic field is perpendicular to the electric field direction inside the GEM chamber, electron avalanche in the gas gaps drifts at some angle (the Lorentz angle) with respect to the normal to the readout board. The electron cloud drift results in a displacement of the collected charge, which is called Lorentz shift. The shift value depends on the field strength and gas properties. To eliminate a systematic shift of the reconstructed tracks in the magnetic field, GEM detectors are oriented in alternating order so that the electric field for the neighboring planes has opposite directions (see Fig. 3.3.5).

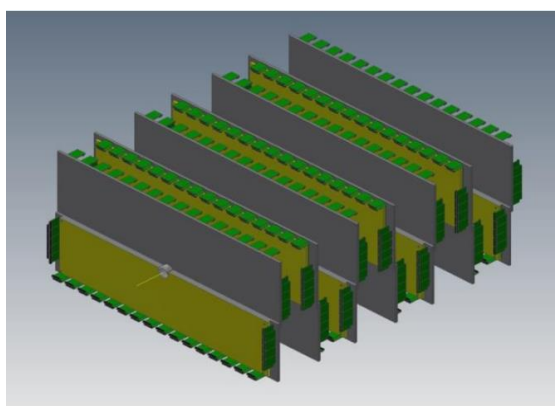

Fig. 3.3.5. A technical drawing of the BM@N GEM tracking system.

The full configuration with 14 GEM detectors (~90000 readout channels) is planned to be integrated in the BM@N experimental setup at the middle of 2021 with the electronics based on VA-163 chips.

The development of the mechanics design to provide GEM planes precise installation inside the magnet was performed by Ltd «Pelcom-Dubna» (Dubna, Russia) (see Fig. 3.3.6). The production of the mechanics will be performed till autumn 2021.

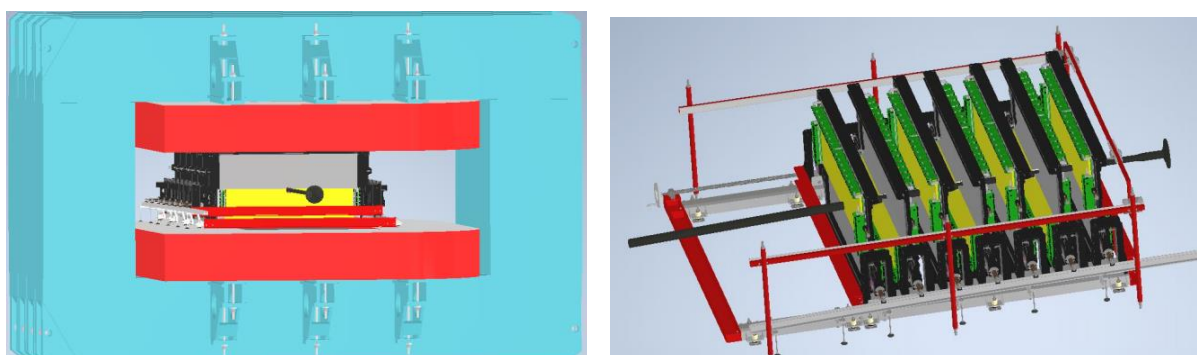

Fig. 3.3.6. A design of the mechanics for GEM planes precise installation inside SP-41 magnet

Material budget for the GEM central tracking system full configuration together with electronics and support mechanics was estimated (see Fig. 3.3.7).

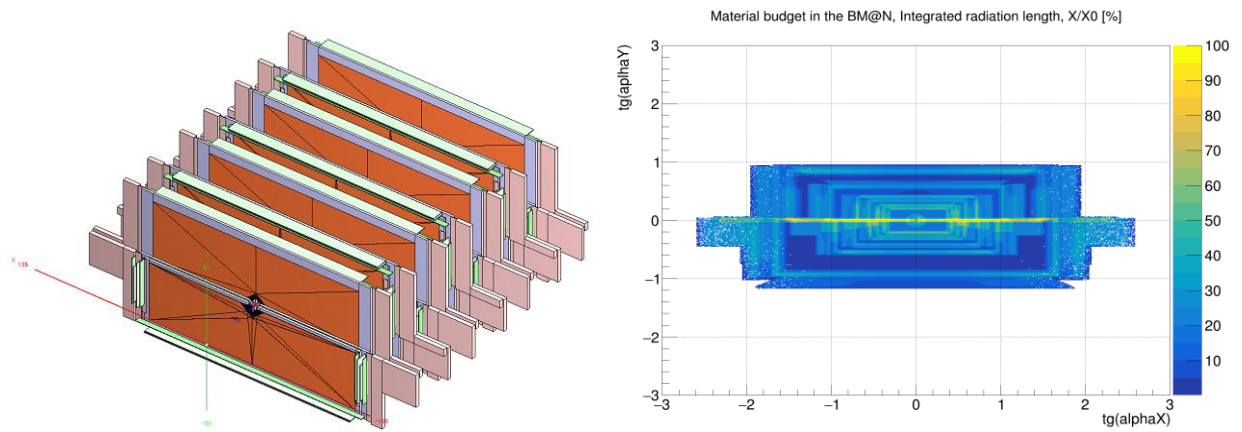

Fig. 3.3.7. Left panel: Detailed geometry of GEM planes for heavy ion beam run. Right panel: Material budget of the GEM central tracking system full configuration (angular distribution).

The performance and characteristics of the GEM detectors were studied in articles [3.3.1-3.3.10] and presented in the TDR report [3.3.11].

3.3.2 Forward silicon detectors

Forward silicon detectors FwdSi are installed between the target and the GEM stations to increase the tracking efficiency and improve the precision of the primary vertex reconstruction. The results of simulation of the hybrid central tracking system based on FwdSi and GEM detectors are presented in section 3.2.2. The schematic views of the silicon detector modules and the silicon detector planes are given in figure 3.3.8. Fast signals from readout chips of the segmented SiD trigger detector situated in front of FwdSi will form a trigger signal for multi-particle events (see section 3.7.2).

Design of the existing Forward Silicon Detectors

Forward Silicon Detectors FwdSi consist of three planes combined from two half planes (Fig. 3.3.8). Each half-plane has a hole for a beam pipe, inlet and outlet for the cooling system (cold dry air), and cross-boards for connection with the DAQ system and power supply. The details of the existing FwdSi detectors are described in document [3.3.12]. The relevant numbers for Forward Silicon Detectors are presented in Tab.3.3.2.

A silicon detector module consists of two DSSDs, which are wire bonded strip to strip. The detector sensitive volume is $63 \times 63 \times 0.3 \text{ mm}^3$. The pitch for the p^+ (n^+) side is 95 (103) μm . Stereo angle between strips is 2.5 degrees, number of strips for each side – 640 . Since detector does not have integrated capacitors, Pitch Adapter is used to electrically decouple the DC current from the electronic inputs. PA has two different topologies for each DSSD side. Each PA has 640 channels, value of poly-Si resistor is about 1 MOhm , value of integrated capacitor is 120 pF , capacitor working voltage is 100 volts and breakdown voltage more than 150 volts. After PAs signal from detector transfer to VATAGP7.1 ASICs manufactured by IDEAS, Norway (5 chips per module side). The main ASIC parameters are 128 input channels, multiplexed output and dynamic range $\pm 30 \text{ fC}$.

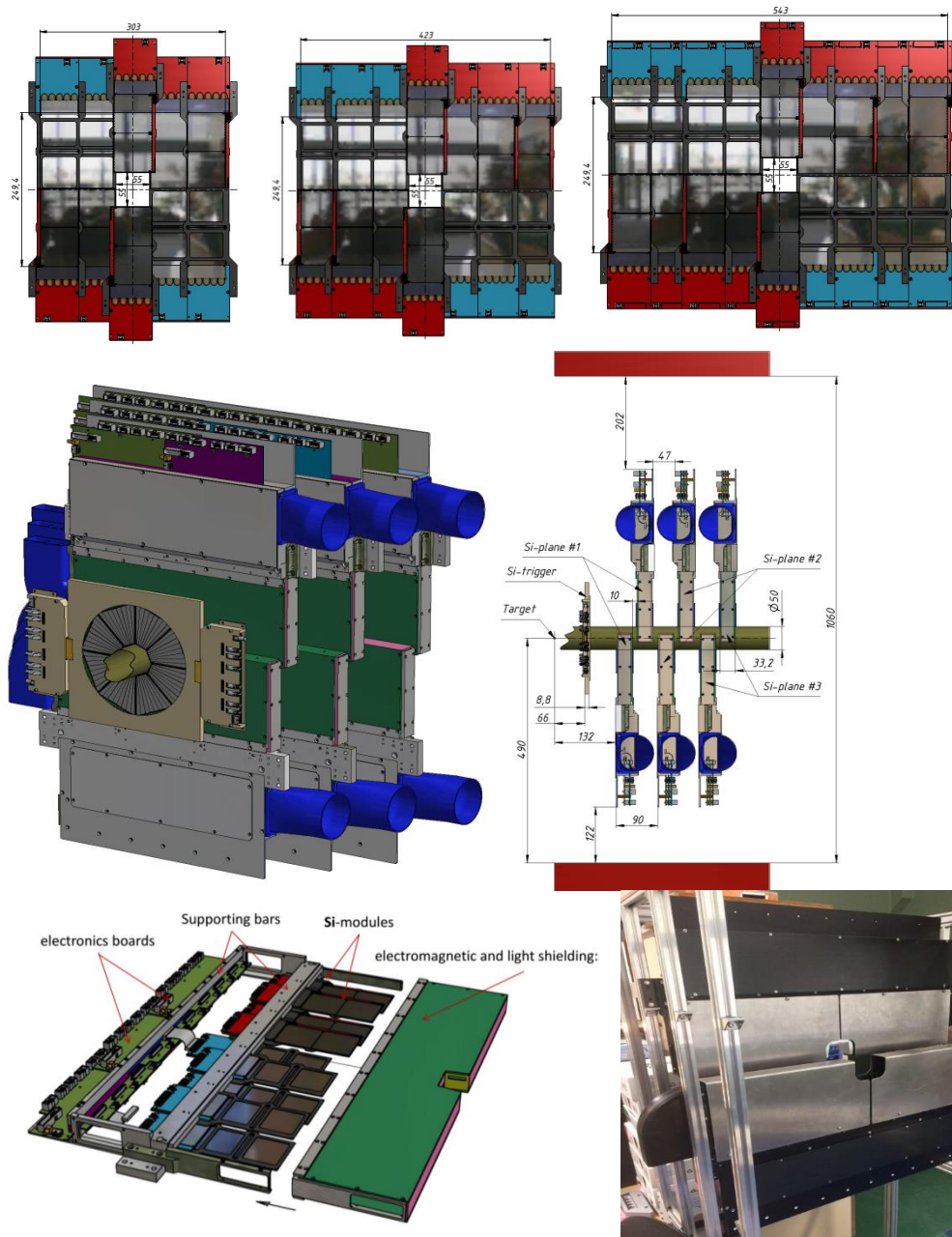

Figure 3.3.8. Schematic view of the silicon detector modules; combined view of the silicon detector plane; the prototype of the mechanical box for the silicon detector installation

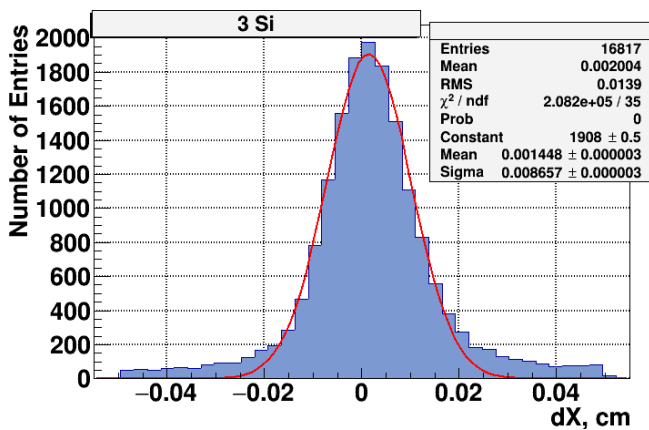

Fig.3.3.9 FwdSi hit to track residuals measured in the argon beam run.

The performance of the FwdSi detectors in argon beam run is illustrated in Fig.3.3.9 showing Si hit to the track residuals. Tracks are reconstructed in a set of FwdSi and GEM detectors.

Forward Silicon Detector upgrade plan

An additional 4th plane of Forward Silicon Detectors will be designed to increase the tracking efficiency and acceptance of the existing FwdSi detectors. The new plane will consist of two half-planes with 11 large area (186x63 mm²) silicon detector modules based on two DSSD with sensitive volume of 93x63x0.3 mm³ (Fig. 3.3.9). Two DSSD are bonded strip to strip by wires. The pitch for the p⁺ (n⁺) side is 95 (103) μm. The stereo angle between strips is 2.5 degrees, the number of strips for each side is 640. The FEE design for the existing FwdSi detectors will be used.

To increase the readout event rate capacity of the FwdSi tracker up to final 50 kHz, a FEE based on TIGER ASIC (INFN, Italy) is considered. The main chip parameters are: 64 input channels, shaping time of 60 and 170ns. The decision on usage of the TIGER ASIC for a new high rate FwdSi FEE will be done after the ongoing R&D.

Table 3.3.2. Relevant numbers for the Forward Silicon Detectors

Number of	First Plane	Second Plane	Third Plane	4 th Plane (after upgrade)	Total (after upgrade)
Si-modules	10 (60x120 mm ²)	14 (60x120 mm ²)	18 (60x120 mm ²)	22 (63x186 mm ²)	42 (64)
DSSDs	20	28	36	44	84 (128)
ASICs (temp. <= +25 C°)	100	140	180	220	420 (640)
Power dissipation, W	28.16	39.42	50.69	61.95	118.27 (180.2)
PAs	20	28	36	44	84 (128)
FEE PCBs	20	28	36	44	84 (128)
Channels	12800	17920	23040	28160	53760 (81920)
Area, m ²	0.073	0.102	0.132	0.257	0.307 (0.564)

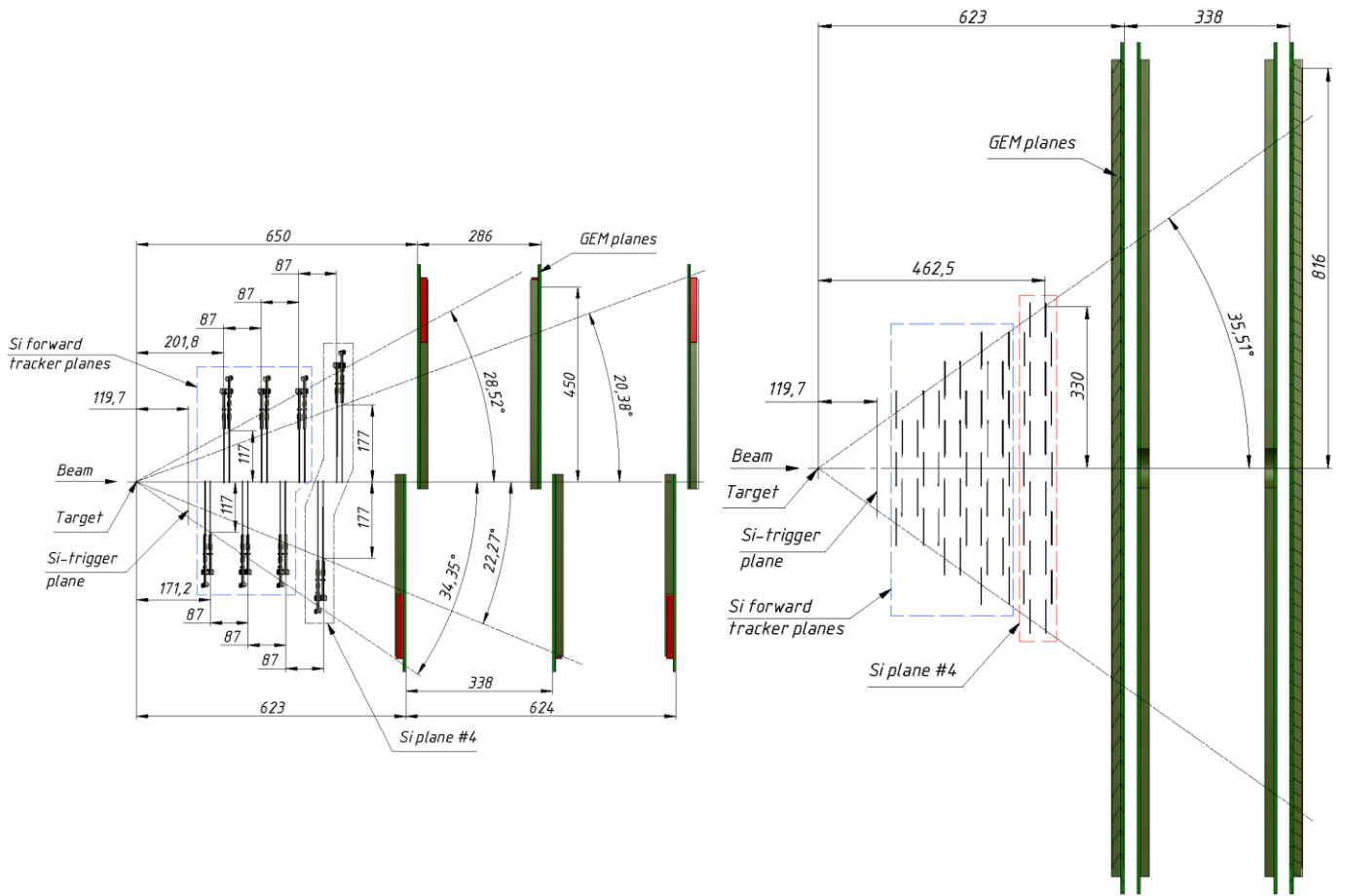

Figure 3.3.9. Schematic view of Forward Silicon detectors including 4th Si plane and first large aperture GEM stations in YZ (left) and XZ (right) projections.

3.3.3 STS tracker

In 2022 BM@N experiment will be upgraded in order to fit occupancy challenge of Au+Au collisions with beam energies up to 4.5A GeV. A new hybrid tracking system based on four large aperture stations of double-sided microstrip silicon sensors of high granularity followed by 7 planes of two-coordinate GEM detectors and a vacuum beam pipe will be installed. Results of the physics performance simulations of the hybrid tracker are presented in [3.3.13]. Silicon planes are currently under development following the design used for the STS of the CBM experiment. The BM@N STS project will be performed in two steps: firstly, two stations with 44 modules will be assembled, installed and commissioned at the end of 2022, the full configuration will be ready in 2023-2024 provided priority given to the BM@N STS and not to the CBM STS project since they both share same module assembly line at VB LHEP.

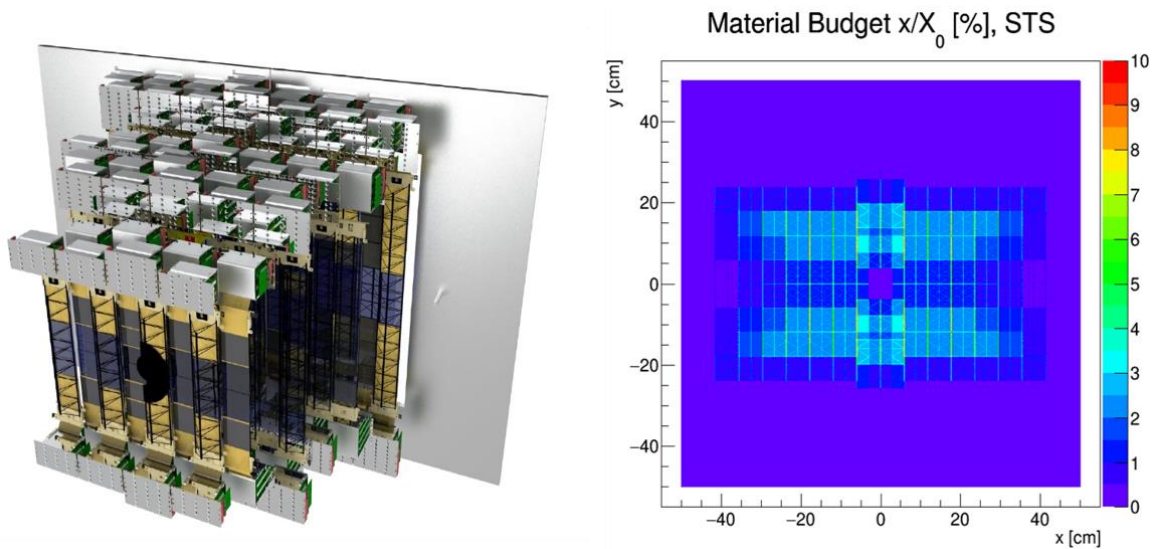

Fig. 3.3.3.1 Left panel: Layout of the BM@N STS detector. **Right panel:** space distribution of the total material budget for four STS stations

The Silicon Tracking System (STS) of the BM@N consists of four stations equipped with 292 double-sided micro-strip silicon sensors providing information on the position, time and energy released by the particle passing through a sensor of the STS. The STS configuration is described in details in [3.3.14]. STS sensors of two sizes are used: 42 mm x 62 mm, and 62 mm x 62 mm. The sensors have a thickness of $320 \pm 15 \mu\text{m}$. Each sensor has 1024 strips on each side with a strip pitch of 58 μm . Strips on the N-side of the sensor are straight, while the strips on the P-side are titled at an angle of 7.5° relative to the strips on the opposite side. Consequently, the minimum sensitive area of the sensor for a two-coordinate spatial measurement, i.e. a “pixel” has a size of $\Delta x = 58 \mu\text{m}$ times $\Delta y = 58 \mu\text{m}/\tan(7.5^\circ) = 440.6 \mu\text{m}$. Short angled strips located on both edges are connected via a second metallization layer on the P-side.

The 2048 strips of each sensor (P and N side) are readout simultaneously by 16 ASICs sitting on 2 Front-End Boards (FEBs). Each ASIC is connected to the sensor via 2 low-mass aluminum-polyimide micro-cables, each reading out 64 strips. These cables, which vary in length between about 15 and 35 cm depending on the position of the sensor and the size of the station, allow to locate the readout electronics at the periphery of the station. This is required for two reasons: Firstly, the material budget of the active detector area, and, hence, the scattering of the particles is strongly reduced. Secondly, the radiation sensitive circuits of the readout electronics are positioned in a region of much lower particle density. The unit consisting of a sensor, 32 cables and a FEB is called a *module*. Several modules are mounted on ultralight spaceframes, *the trusses*, made of high modulus carbon fiber. This super module, consisting of up to 10 modules with readout micro-cables transmitting the signals in both directions (up and down), is the so-called *ladder*. The stations 1, 2, 3, and 4 comprise 24, 52, 64, and 104 modules, respectively, with sensors of size $62 \times 62 \text{mm}^2$. In the inner part of each station, 8 modules with sensors of size $42 \times 62 \text{mm}^2$ are located. Four modules with *central sensors* of size $42 \times 62 \text{mm}^2$ with cut edges cover the space close to the beam pipe, in order to detect the particles emitted at the smallest scattering angles.

The layout of the STS is shown in the left panel of Fig.3.3.3.1. The first station is located 30 cm downstream the target. The distance between all STS stations is 20 cm. The sensors on the ladders are tiled with an overlap of 1,3 mm to cover the existing 1 mm wide dead area at the edges of the sensors. The ladders in the center of the stations form a semicircle opening which will finally, when all stations are installed in a mainframe, form a bore in the STS for the placement of the vacuum carbon fiber beam pipe transporting the incident beam through the STS to the beam dump. The space distribution of the material budget for all STS stations is shown in the right panel of Fig.3.3.3.1. The total material budget does not exceed 10% of X_0 , while the average value is $\sim 3\%$ of X_0 .

Physics Performance Simulations

The reconstruction performance of the hybrid tracker of BM@N was studied for the lambda-hyperon, as a bench-mark observable. The reconstruction efficiency of the primary tracks as a function of momentum is shown in the left panel of Fig.3.3.3.2. The reconstruction efficiency of the STS is better than 90% for the particles with momentum above 0.6 GeV/c. The hybrid tracker efficiency drops to the value about 80% at 6 GeV/c. The reason for the lower efficiency of the hybrid system is a lower granularity of the GEM detectors. The momentum resolution as a function of momentum for the hybrid tracker is shown in the right panel of Fig.3.3.3.2. The momentum resolution is better than 0.6 % for the momentum above 0.5 GeV/c. The Lambda reconstruction efficiency is slightly above 10 % for the hybrid tracking system.

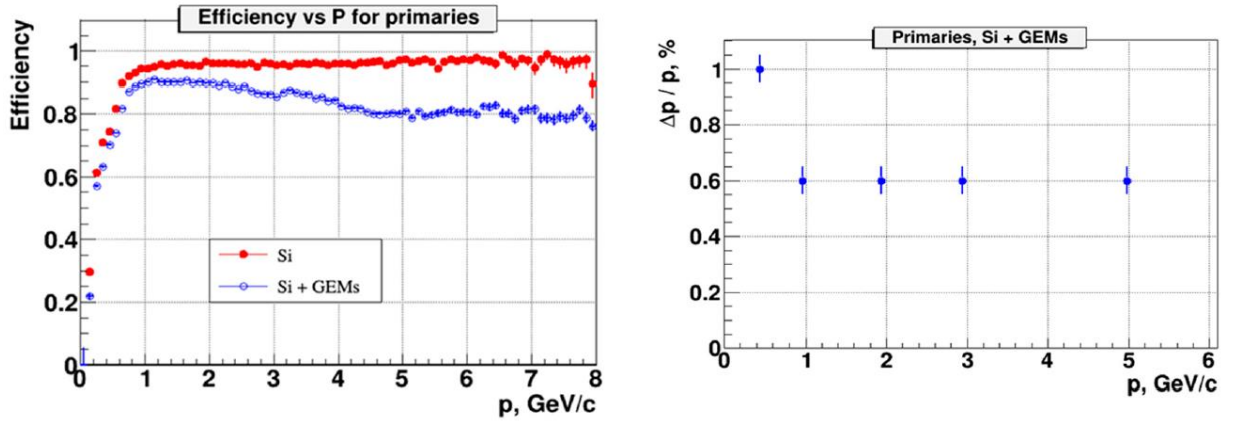

Fig.3.3.3.2 Left panel: Reconstruction efficiency as a function of 4 hits in the Si stations only (red histogram), and in the Si + GEM stations (blue histogram). **Right panel:** Momentum resolution for primary tracks emitted in the central Au + Au collisions at a beam kinetic energy of 4 A GeV reconstructed by the BM@N hybrid tracking system as a function of momentum.

Radiation calculations

The radiation calculations were performed with FLUKA assuming a gold beam with energy 4.5 AGeV, a profile with $\sigma=3.5$ mm and a divergence of 1 mrad and intensity 2 MHz. In the simulations, the beam permeates the setup in a vacuum thin-wall beam pipe with the walls made of carbon fiber.

Simulations have shown, that in the region of STS the total ionizing dose for the whole lifetime of the experiment will reach 100 Gy. The equivalent neutron fluence for the same period will be 10^{11} n_{eq}/cm^2 . Both values are well within the radiation tolerance of the sensors [3.3.15].

STS Modules

The key component of the STS is a module. Each sensor has 1024 strips on both sides. They are connected to the readout ASICs via low-mass aluminum-polyimide micro-cables. A total of 8 STS-XYTER ASICs [3.3.16] are needed to carry out signals from one side of the sensor. ASICs are installed on the Front-End Boards (FEBs) that are equipped with specially developed LDOs with a low noise density. The main constrain of the module is its very tight layout. Strips on the sensor have a pitch of 58 μm and for the readout of the analog signals, micro-cables with a 100 μm pitch of signal lines were developed. A photo of the assembled module is shown in Fig. 3.3.3.3.

The assembling of the module comprises TAB-, die- and wire-bonding procedures, as well as alignment and gluing steps described in [3.3.14]. Bonding procedures are performed with a help of ultrasonic bonding machines F&K Delvotec G5. A photo of the assembly procedure as well as bonding test procedure is shown in Fig. 3.3.3.4.



Fig. 3.3.3.3 Photo of the STS module without the shielding foils. The sensor on the left side is connected to the readout electronics on the right side with low-mass micro-cables.

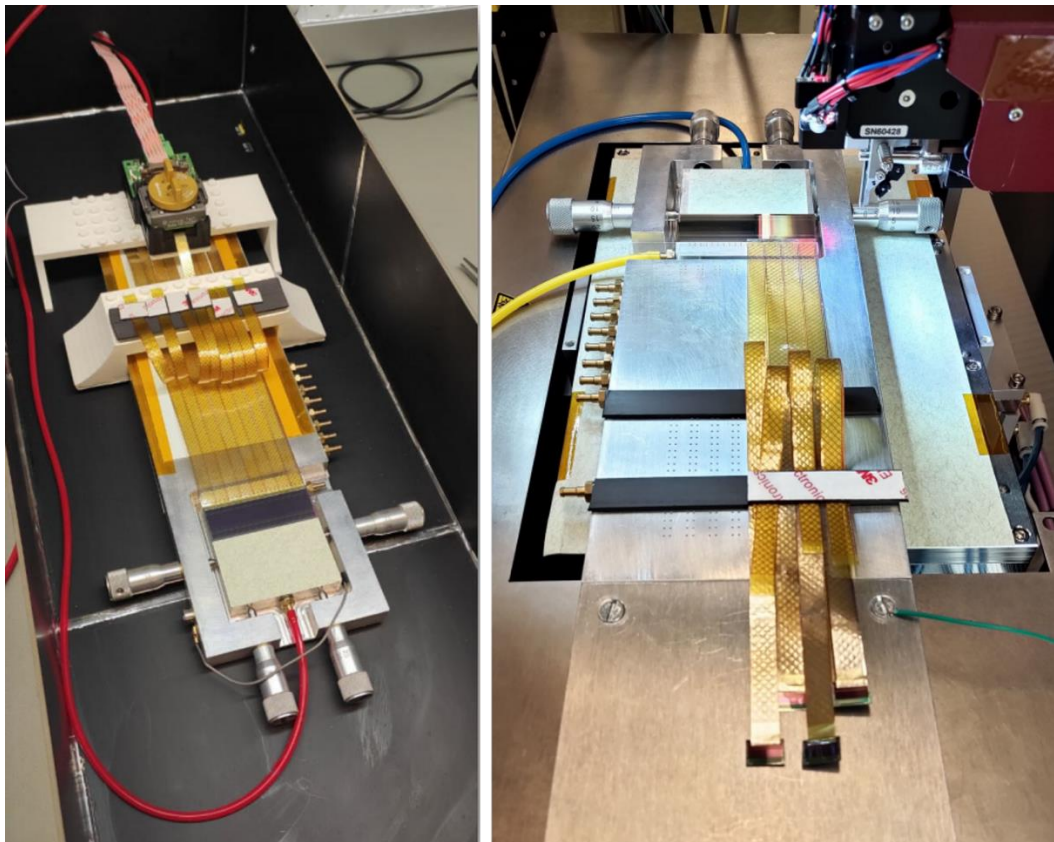

Fig. 3.3.3.4 Left: Photo of the bonding test procedure, which is performed after each step of the assembly. **Right:** TAB-bonding of the micro-cables to the sensor.

Ladder assembly

The ladder is a “super-module” of the STS. It consists of several modules attached to the ultra-light carbon-fiber spaceframe. Each spaceframe has a custom-designed bearing on both sides. The bearings provide a precise positioning of the ladder on the mechanical support frame with an experimentally tested accuracy of $\sim 2 \mu\text{m}$ in the directions across the beam line. Precise positioning is guaranteed by the system with ruby ball pins on the ladder support frame, and a customized reply part of the ladder positioning units glued to the edges of the carbon-fiber spaceframe to which the sensors are glued with the help of tiny L-legs made of fiberglass. The FEBs, two for each module, are placed inside the aluminum FEB-boxes, located on both sides of the ladder. The FEB-box provides a thermal interface between readout electronics and the heat exchanger plate. The layout of the BM@N ladder is shown in Fig.3.3.3.5, photo of the ladder assembly process is shown in Fig.3.3.3.6.

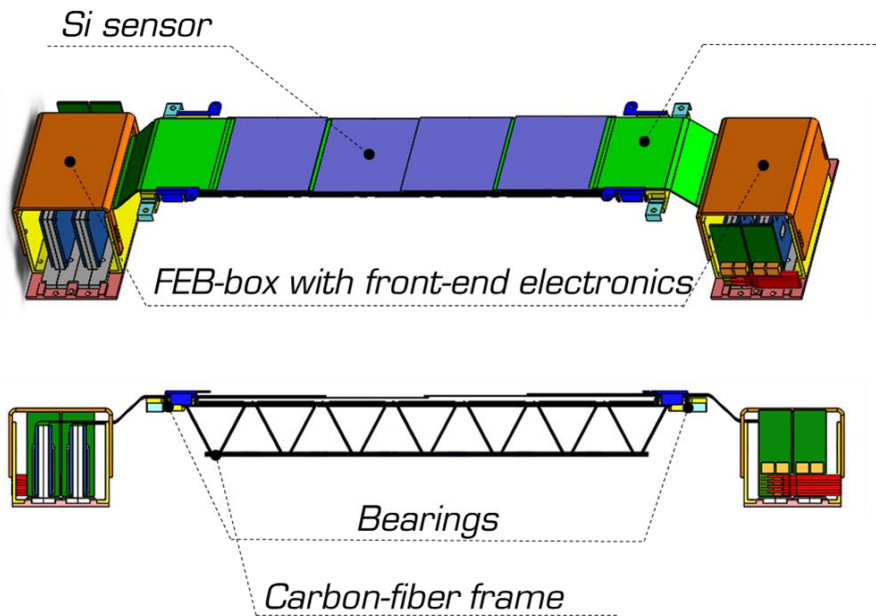

Fig.3.3.3.5. Layout of BM@N ladder.

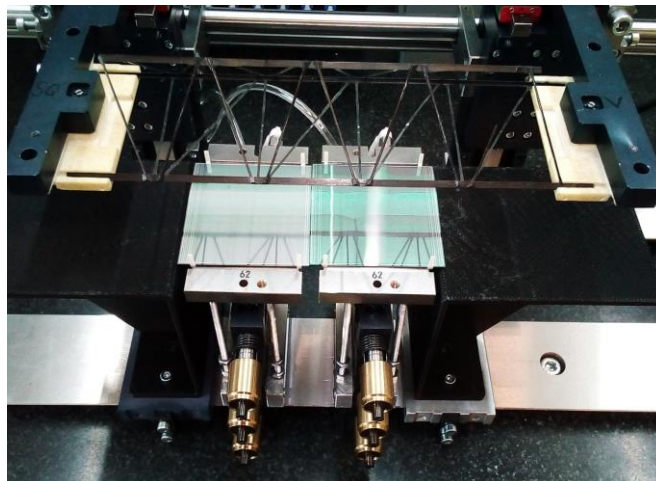

Fig.3.3.3.6. Ladder assembly.

The central part of the ladder comprises the sensors installed on the light CF frame. The frontend electronics is located on the both sides of the frame in aluminum FEB boxes. The assembly of the ladder is a delicate procedure, which requires a precise positioning of the modules. For that reason, a special Ladder Assembly Device (LAD) was developed. The LAD with a customized set of fixtures was produced at PLANAR, Ltd. Enterprise (Minsk) and installed at JINR in the end of 2019. It is equipped with an optical system for monitoring the sensor position in a horizontal plane with an accuracy of $\pm 2\mu\text{m}$. For the alignment of the sensors it comprises different sets of sensor-positioning vacuum chucks with micro-screws and a lift unit for the vertical displacement of the ladder sensor supporting carbon-fiber spaceframe. The LAD is installed on a heavy diabase table to avoid vibrations during its operation. The LAD provides an accuracy of sensor positioning of less than $15\ \mu\text{m}$ across the ladder on the 1200 mm base.

Readout electronics of BM@N STS

The data acquisition chain of the BM@N STS conceptually exploits the free-streaming readout scheme being developed for the CBM [3.3.17]. The frontend electronics of the STS is an integral part of the module that relies on the STS-XYTER ASIC developed by the CBM

collaboration. Each ASIC provides 128 channels operating in a self-triggered mode. The ASIC provides a 5 bits amplitude and 14 bits time stamp information for each hit frame. The ASICs communicate with the system through the configurable multichannel e-link protocol. The maximum hit rate per one channel in the BM@N STS setup is ~20 kHz/channel.

To provide a bi-directional optical link between the front-end electronics and data-processing units GBTxEMU boards are used. The GBTxEMU boards are equipped with Artix-7 FPGA produced by XILINX. Each board hosts firmware emulating the functionality of CERN GBTx ASIC.

Data processing is performed on the level of GBTxEMU Readout Interface (GERI) boards. These boards play a role of the back-end optical interfaces for the GBTxEMUs, and are equipped with a Virtex-7 FPGA from Xilinx. The data are sorted on the time-base and trigger decision, and are further transmitted to the global BM@N DAQ system.

References:

[3.3.1] A. Galavanov et al., «Large area BM@N GEM detectors». The 6th International Conference on Micro Pattern Gaseous Detectors (MPGD19) proceeding. Journal of Physics: Conference Series (JPCS) 2020 1498 012043.

[3.3.2] Васильев С.Е. и др., «Исследование характеристик GEM детекторов эксперимента BM@N». Письма в ЭЧАЯ, ISSN:1814-5957, eISSN:1814-5973. Т. 16, № 6 (225). С. 643-652.

[3.3.3] A. Galavanov et al., «Status of the GEM/CSC tracking system of the BM@N experiment». International Conference on Instrumentation for Colliding Beam Physics (INSTR20) proceeding. Journal of Instrumentation 15 C09038 (2020).

[3.3.4] A. Galavanov et al., «Performance of the BM@N GEM/CSC tracking system at the Nuclotron beam». XXIVth International Baldin Seminar on High Energy Physics Problems proceeding. EPJ Web of Conferences, 204 (2019) 07009.

[3.3.5] A. Galavanov et al., «Study of the BM@N GEM/CSC Tracking System Performance», The XXIII International Scientific Conference of Young Scientists and Specialists (AYSS-2019) proceeding. AIP Conference Proceedings 2163, 030003 (2019).

[3.3.6] S. Bazylev et al, «Study of the GEM detector performance in BM@N experiment». The XXI International Scientific Conference of Young Scientists and Specialists (AYSS-2017) proceeding. EPJ Web Conf., 177 (2018) 04004.

[3.3.7] M. Kapishin et al., «GEM Detector Performance Assessment in the BM@N». International Conference «Mathematical Modeling and Computational Physics» (MMCP 2017) proceeding. EPJ Web of Conferences, 173(2018), 04007.

[3.3.8] D.A. Baranov et al., «First Results from BM@N Technical Run with Deuteron Beam», Physics of Particles and Nuclei Letters, ISSN:1547-4771, eISSN:1531-8567, Изд:MAIK Nauka/Interperiodica distributed exclusively by Springer Science+Business Media LLC.

[3.3.9] D. Baranov et al., «GEM tracking system of the BM@N experiment». International Conference on Instrumentation for Colliding Beam Physics (INSTR17) proceeding. Journal of Instrumentation, Volume 12, ISSN:1748-0221, June 2017.

[3.3.10] S. Bazylev et al., «Triple GEM tracking detectors for the BM@N experiment». The 3rd International Conference on Particle Physics and Astrophysics (ICCPA 2017) proceeding. Knowledge E, KnE Energy & Physics, ISSN: 2413-5453, p. 268-274.

[3.3.11] http://bmnshift.jinr.ru/wiki/lib/exe/fetch.php?media=tdr_gem_may2017_v1.doc

[3.3.12] http://bmnshift.jinr.ru/wiki/lib/exe/fetch.php?media=forward_silicon_for_tdr.doc

[3.3.13] Senger P., Dementev D., Heuser J., Kapishin M., Lavrik E., Murin Y., Maksymchuk A., Schmidt H.R., Schmidt C., Senger A., Zinchenko A. Upgrading the Baryonic Matter at the Nuclotron Experiment at NICA for Studies of Dense Nuclear Matter // Particles 2019, 2. p.481-490.

[3.3.14] A. Baranov et. al. (The BM@N STS group) The Silicon Tracking System as Part of the Hybrid Tracker of the BM@N Experiment: Technical Design Report // Dubna: JINR, 2020. 101 p.

[3.3.15] J. Momot, Characterization and radiation hardness studies of the silicon microstrip sensors for the CBM experiment // Ph.D. Thesis, Goethe U., Frankfurt (main) (2019).

[3.3.16] K. Kasinski, R. Kleczek, P. Otfinowski, R. Szczygiel and P. Grybos STS-XYTER, a high count-rate self-triggering silicon strip detector readout IC for high resolution time and energy measurements // IEEE Nuclear Science Symposium and Medical Imaging Conference (NSS/MIC), Seattle, WA, 2014. p. 1-6.

[3.3.17] J. Lehnert, A.P. Byszuk, D. Emschermann, K. Kasinski, W.F.J. Müller, C.J. Schmidt, R. Szczygiel, W.M. Zabolotny GBT based readout in the CBM experiment // 2017 JINST 12 C02061.

3.5 Outer tracker

The purpose of the outer tracker is to provide link between tracks measured in the central tracker and hits in the ToF-400 and ToF-700 detectors. Initially it consisted of two large aperture drift chambers. Every drift chamber (DCH) consists of 4 double coordinate planes with the following parameters: the wire inclination angles of 0, 90, $\pm 45^\circ$, the wire pitch of 10 mm, the outer dimensions of the sensitive area of $Y_{\text{out}} \pm 1.2$ m, $X_{\text{out}} \pm 1.2$ m, the beam hole radius of $R_{\text{min}} = 10$ cm, 256 wires per coordinate plane, 2048 wires per chamber. The granularity of DCH is sufficient to perform measurements of interactions with light ions (up to Ar). The DCH wire occupancy in interactions of middle and heavy nuclei is too high to perform efficient track separation. Thus, the DCH will be replaced by cathode strip chambers to perform track measurements in middle and heavy nucleus collisions.

3.4.1 Cathode Strip chambers

The full configuration of the outer tracking system for heavy ion program will consist of four planes of 1129×1065 mm² CSC (cathode strip chamber) and two planes of 2190×1453 mm² CSC. The CSC detectors are situated outside the magnetic field with the aim to make precise link to the tracks, reconstructed in the GEM detectors inside the analyzing magnet. Tracks refined in CSC are used to improve particles momentum reconstruction and to find corresponding hits in the time-of-flight systems ToF400 and ToF700.

The first CSC detector with the size of the active area of 1129×1065 mm² was designed and assembled at LHEP JINR in 2018. It consists of an anode plane located between two cathode planes (see Fig. 3.4.1a). The anode plane is a set of gilded tungsten wires with the diameter of 30 μm which are fixed on the plane with a step of 2.5 mm. The gap between the anode plane and each cathode plane is 3.8 mm. There is a spacer between the cathode planes to prevent deformation of the chamber due to the gas pressure inside. The anode wires are supported by two special wires strained across in the middle. Both cathode planes are made from PCBs (printed circuit boards). A two-coordinate readout of the signal is performed on two cathode boards using sets of parallel metal strips. The inclination angles of the cathode strips to the vertical axis are 0 degrees (X coordinate) and 15 degrees (Y coordinate). The pitch of the X and Y strips is 2.5 mm. PCBs are

glued to the support honeycomb. Due to the a large multiplicity of charged particles in Au-Au collisions, readout layer is divided into outer (cold) and inner (hot) zones.

First beam tests of the $1129 \times 1065 \text{ mm}^2$ CSC were performed in 2018 at the argon beam with kinetic energy of 3.2 AGeV and the krypton beam with kinetic energy of 2.3 AGeV at the Nuclotron. The CSC was installed upstream the ToF-400 time-of-flight detectors as it is shown in Fig. 3.4.1b. The main goal of the tests was to study the performance of the CSC detector and the FEE and readout electronics as a part of the BM@N experimental setup. The CSC was filled with the flowed Ar(75)/C₄H₁₀(25)/C₃H₈O(vapor) gas mixture and equipped with the VA163 based electronics. The signal clusters were reconstructed as groups of adjacent strips with amplitudes of signals above the threshold. For the reconstructed clusters, the center of gravity, the width and the total charge were calculated. The average cluster width is 6 strips which is equal to 15 mm. The gap size between the anode and cathode is reduced to 3 mm instead of 3.8 mm in order to improve the spatial resolution in multitrack events.

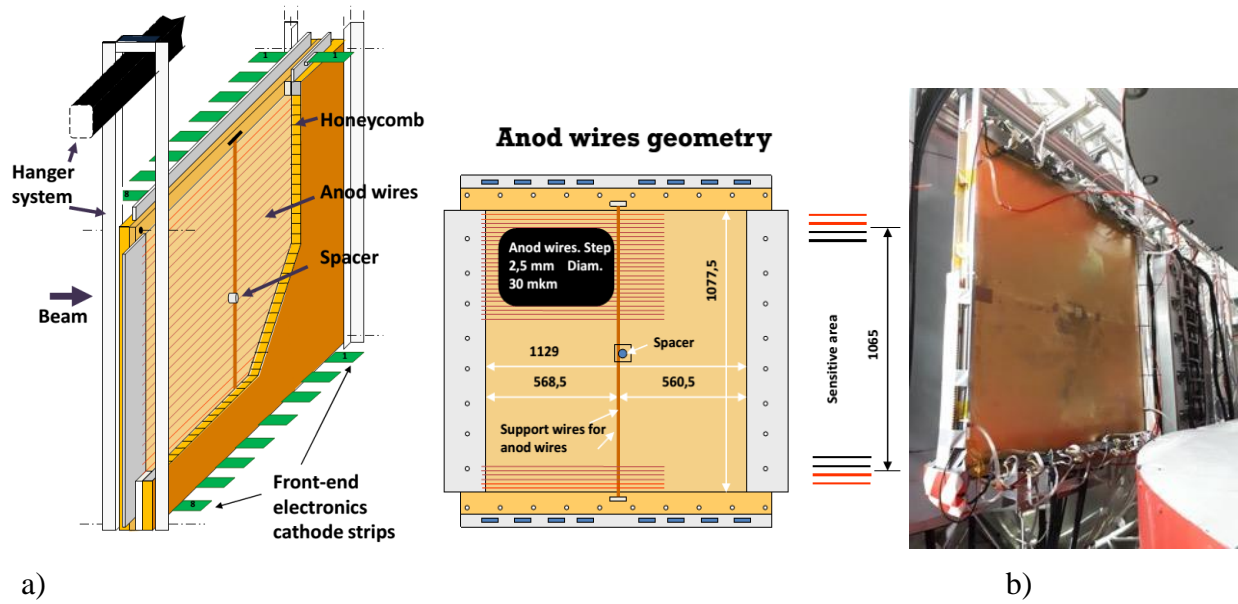

Fig. 3.4.1 a) Schematic cross section of $1129 \times 1065 \text{ mm}^2$ CSC b) $1129 \times 1065 \text{ mm}^2$ CSC integrated into the BM@N experimental setup.

Tracks of charged particles were reconstructed in the GEM central tracking system and extrapolated into the CSC. The efficiency distribution over the chamber surface is presented in Fig. 3.4.2 (left). The efficiency for the area $y < -5 \text{ cm}$ was not estimated because of the relative location of the CSC and GEM detectors: the GEM detectors were covering the phase space only above the beam. The yellow vertical strip at $x = 110 \text{ cm}$ is an effect of the support wires. The green area at the left upper corner is due to a problematic front-end board. The combined tracks reconstructed from GEM and CSC hits were extrapolated to the TOF-400. Such procedure improves the momentum resolution and helps to separate secondary particles (π , p, K, light nuclei) in the momentum range 0.5-3.5 GeV/c (see Fig. 3.4.2, right).

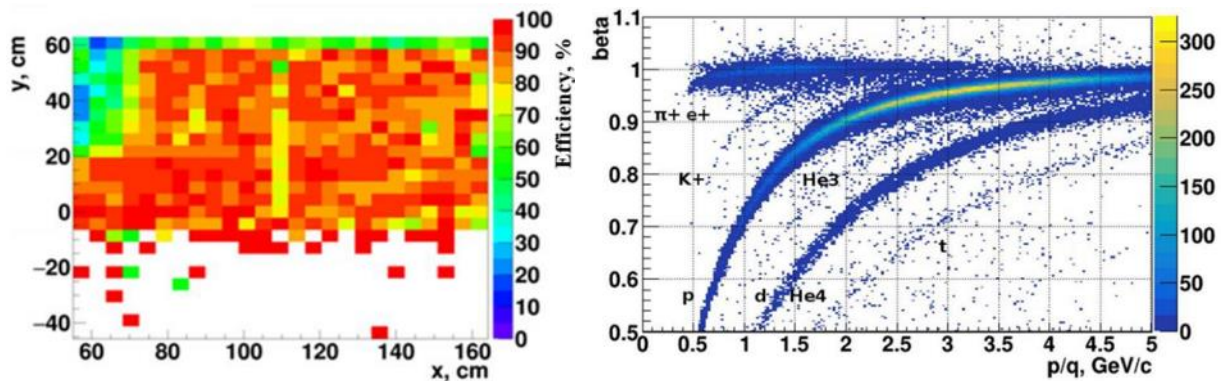

Fig. 3.4.2. Efficiency distribution for CSC (left); preliminary particle identification of GEM+CSC tracks extrapolated to the ToF-400 (right).

All components for the assembly of three 1129×1065 mm² CSCs are delivered to JINR. The assembly process of three 1129×1065 mm² chambers is at the final stage. After passing quality assurance and cosmic tests three 1129×1065 mm² CSCs will be integrated into the BM@N setup in the middle of 2021.

Two CSCs of the size 2190×1453 mm² have been designed to cover the ToF-700 system on both sides and replace the existing DCH chambers. The design of these cathode strip chambers is shown in Fig. 3.4.3. One cathode plane consists of 8 PCBs, each PCB is divided into hot and cold zones. The hole in the center of the chamber is designed for the vacuum beam pipe. The gap size between the anode and cathodes is planned to be 3 mm. A two-coordinate readout of the signal is performed using sets of parallel metal strips with the inclination angle of 0 degrees for the X coordinate and 15 degrees for the Y coordinate. The pitch of the X and Y strips is 2.5 mm.

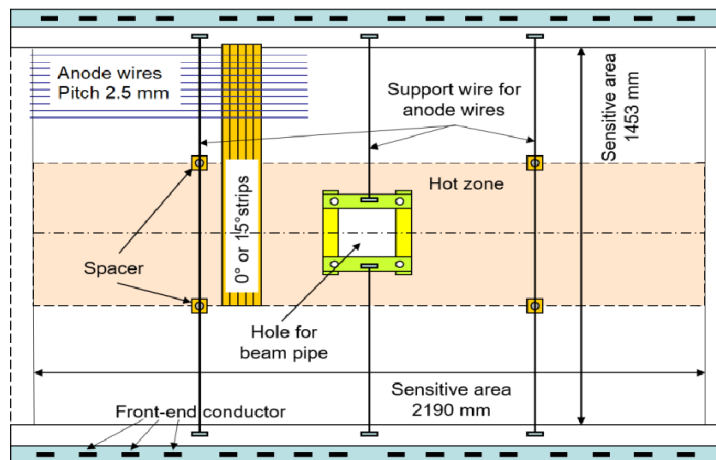

Fig. 3.4.3 A technical drawing of the cathode strip chamber of the size 2190 × 1453 mm² (15-degree strips are not shown in this picture).

The design of the 2190×1453 mm² CSC cathode planes was developed and VBLHEP JINR. The production was performed by “Mettatron group”. The technological equipment for the assembly is under development. The assembly process of the first 2190×1453 mm² CSC is planned to be finished by the end of 2021 and of the second one – in the middle of 2022.

Front-end electronics

Front-end electronics is based on the charge sensitive pre-amplifier chip VA163 produced by IDEAS – Integrated Detector Electronics AS (Norway). The chip has 32 channels. Each channel contains a charge-sensitive preamplifier, a shaper with 0.5 μs (VA-163 chip) peaking time and a sample-hold circuit. An analog multiplexer with 32 inputs allows one to perform serial read-out channel by channel. The chip can be used to amplify and read negative and positive charges in the range from -1.5 pC to +1.5 pC. The equivalent noise charge is 1900e without load, and 2000e at 50 pF input load. The integral linearity is 1% and 3% for the positive and negative charge, respectively. Each read out card includes four chips, which are installed, bonded and filled with black compound. Thus, we have 128 input analog channels read-out board. The multiplexed data from each board are transmitted through the twisted pair flat cable to the 12-bit analog-to-digital converter (ADC) readout by the BM@N data acquisition system.

To improve the performance of the FEE, two new ASICs (VMM3a and TIGER) with the capability to measure both time and amplitude information are considered. First tests of FEE based on both chips have already started. In 2023 the new FEE electronics is planned be integrated into the BM@N experimental setup.

Gas distribution system

The CSC chambers can be operated with Ar(50)/CO₂(50) / C₃H₈O (vapour), Ar(75)/C₄H₁₀(25) / C₃H₈O (vapor) gas mixtures. The gas system consists of two parts: 1) the mixer system which delivers a mixture of gases in a required ratio and pressure to downstream elements; 2) the distribution system, which delivers the gas in well defined quantities to the individual detectors. The gas system is produced by Ltd «Eltochpribor» (Zelenograd, Russia).

High voltage and low voltage supply systems

The HV power system is based on a 12 channel CAEN AG550DN module in CAEN SY5527lc_p create. To power final CSC setup of 6 CSC chambers with the voltage of approximately +3kV 6 channels are needed.

The LV power system is based on NTN 350-6,5 and NTN 700-6,5 LV modules. NTN low voltage module has adapter for a remote control via the Ethernet connection.

The Ethernet control is used to record the high and low voltages values in the BM@N Slow Control System database.

Integration into the BM@N setup

The full configuration with 6 CSC detectors equipped with the electronics based on VA-163 chips (~35000 readout channels) is planned to be integrated into the BM@N experimental setup at the end of 2022. The upgrade of the CSC FEE is planned on 2023.

The performance and characteristics of the CSC detectors were studied in articles [3.3.3-3.3.5]

3.5 ToF system

The time-of-flight (ToF) system is based on the start time T0 detector installed near to the target and two walls of multi-gap resistive plate chambers (mRPC-1,2) situated at distances of around 4 m and 7 m from the target as it is illustrated in figure 3.1.1. The time resolution of the ToF system of 80-100 ps is sufficient to discriminate between hadrons (π, K, p) as well as light nuclei with the momentum up to few GeV/c produced in multi-particle events. Figure 3.5.1 illustrates the resolution of the π/K separation by the ToF detectors and the geometrical acceptance of the mRPC-1,2 walls ToF-400 and ToF-700.

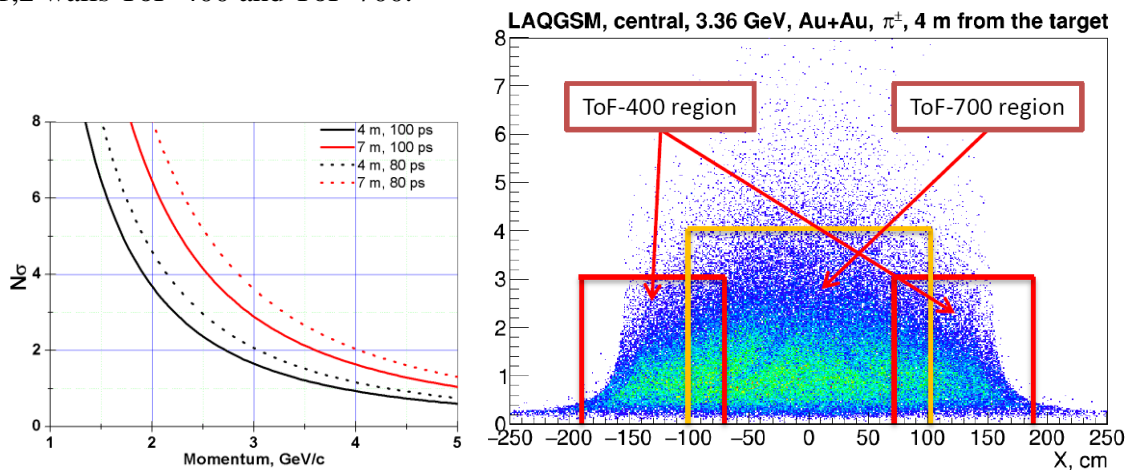

Figure 3.5.1. Left plot: resolution of the π/K separation presented as a function of the particle momentum for two values of the ToF system time resolution and for two distances between T0 and mRPC detectors. Right plot: geometrical acceptance of the ToF-400 and ToF-700 mRPC walls for detection of charged pions produced in central Au+Au collisions.

3.5.1 Start detector T0

The details of the T0 detector design, the start time measurements in beams of light nucleus and heavy nucleus and the measured time resolution are described in section 3.7.1 and in the document [3.7.1].

3.5.2 ToF-400 mRPC detector

The details of the ToF-400 system and the technical parameters of the mRPC's are described in the document [3.5.1]. The schematic layout and the position of the ToF-400 wall are shown in figure 3.5.2(a and b). Time resolution of the TOF400 + T0 system about 80 ps are reached during BM@N Ar+Kr run (fig.3.5.3a). Pion/kaon separation is clear in the momentum range up to 2 GeV/c (fig.3.5.3b). All subsystems work well, but we plan specific upgrade to get best performance of the TOF400. The summary of future work present in the table.

Electronics for ToF-400

The DAQ electronics TDC72VHL are based on HPTDC chip. We plan to modify this modules to reach trigger data rate of 50 kHz. VXS synchronization system by backplane of VME crate should decrease dead time up to 1-2 ns and reduce readout errors. All TDC boards (27 pcs + 10 pcs reserve) are produced in 2017 and will be modified during 2021. It will be the same TDCs with additional back connector and new FPGA program. New TTVXS synchronization module and switches for data taking will be ordered in 2022.

Service systems

To provide high voltage to the ToF modules the 40-channels high voltage system produced by HVSystems is used. The current system is not stable. The remote connection to the HV device was disconnected several times during BM@N data taking. New high voltage system produced by ISEG and WIENER companies (Germany) will be used in future. one MPOD crate will be purchased in 2020. Ten iSeg EHS4080p(n) (4 channels, up to 8 kV and 1 mA) modules will be purchased during 2021. Three low voltage supply modules iSeg MPV 8016I are used to power all FEE of the ToF system.

The mRPC works with a non-flammable Freon-rich gas mixture containing 90% C₂H₂F₄ + 5% i-C₄H₁₀ + 5% SF₆. The simple open gas loop system based on MKS mass flow meters are used. Flows are monitored by a process control computer which continuously calculates and adjusts the mixture percentages supplied to the TOF. The flow of the gas mixture can be adjusted in the range from 6 l/hour up to 90 l/hour. The same system is also used for ToF-700. We plan to produce new distribution module for divide gas flow between TOF400 and TOF700 systems. All main equipment for upgrade is purchased in 2020.

We monitor several parameters as temperature, voltage, current, gas flow and etc for control the Time-of-Flight system of the BM@N. The slow control system has been developed. The data of the slow control system are used during experimental data analysis. All of the slow control equipment components are acquired in 2017.

Mechanical construction

The TOF-400 wall consists of two part (left and right) are placed symmetrical to the beam. Every part consist of two gas boxes (modules) which contain 5 mRPCs each. Gas box made from aluminum frame covered by aluminum honeycomb for reduction of radiation length, but the edge of the gas box are still thick. The new design of gas box will be developed.

Gas boxes are installed on aluminum frame made from circular profile. This shape is not useful for CSC chambers which plan to be installed in 2021. New frame from Bosch profiles will be designed.

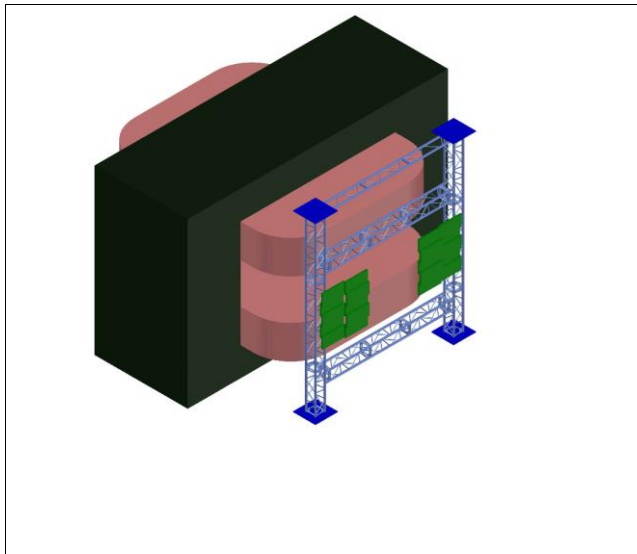
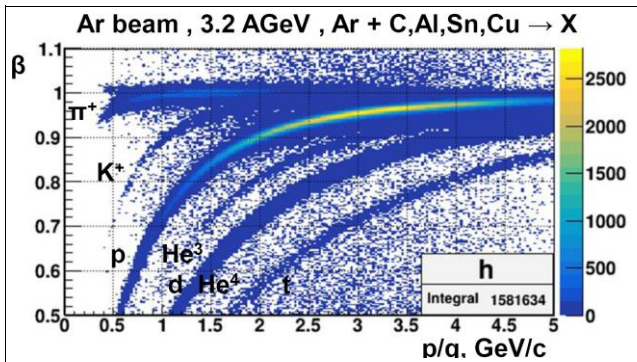

Fig. 3.5.2a Schematic layout of the ToF-400 mRPC wall and its position behind the analyzing magnet.



Fig. 3.5.2b Real view of a half part of the TOF400 system



3.5.3a. Particle $\beta=v/c$ versus momentum identification plot.

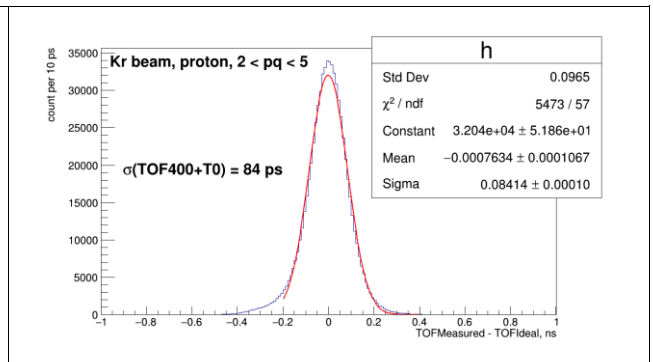

3.5.3b Time resolution of the TOF400+T0 systems

3.5.3 ToF-700 mRPC detector

Time-of-flight detector ToF-700 placed at about 7m from the target provides BM@N with the pion/kaon separation up to 3 GeV/c and proton/kaon separation up to 5 GeV/c. ToF-700 system consist of 58 glass multigap Timing Resistive Plate Chambers (mRPC). The wall size of $3.2 \times 1.6 \text{ m}^2$ is defined to satisfy the geometrical acceptance of the tracking detectors. High resolution of $\sim 60 \text{ ps}$ was achieved with an efficiency above 97% and a crosstalk signal in the adjacent strips is about few percent.

Design of the ToF-700 wall

Conventional glass mRPC suffers from serious shortcomings – low hit rate capability. There are two ways to decrease the resistivity of “window” glass – to minimize its thickness or/and to heat the glass electrode. Our studies showed that the “warm” mRPC can provide us with good time resolution even at a rate of $\sim 20 \text{ KHz}/\text{cm}^2$.

Two types of mRPC were chosen for the construction of the wall plane: a “warm” mRPC for the central “hot” region with high rate of tracks, and a conventional “cold” mRPC for the “cold” region with low rate of tracks. An arrangement of 58 mRPCs in the wall plane is shown in Fig. 3.5.4. The hole in the wall center is for the beam pipe.

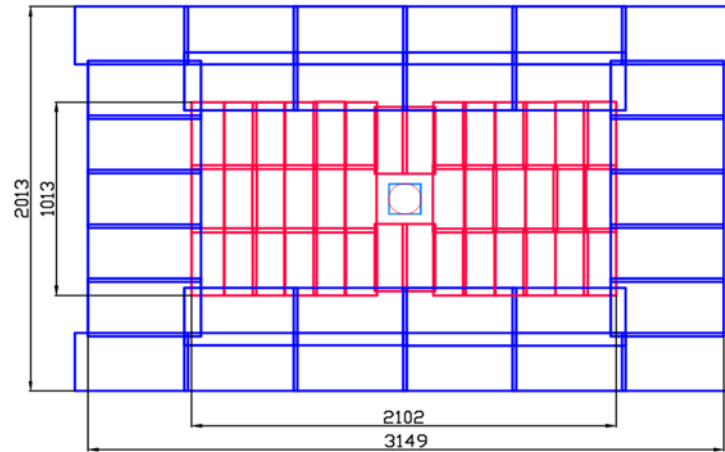

Fig. 3.5.4. Arrangement of 40 “warm” and 18 “cold” mRPCs on the wall plane.

mRPC’s design and assembling

To optimize the number of chambers types and sizes, two types of mRPC were proposed: 18 “cold” mRPCs, each with the active area of $17.6 \times 56 \text{ cm}^2$ (16 strips of $1 \times 56 \text{ cm}^2$), for the region with the low hit rate and 40 “warm” mRPCs, each with the active area of $16 \times 35.1 \text{ cm}^2$ (32 strips of $1 \times 16 \text{ cm}^2$) for the region with the high hit rate and occupancy. The total number of chambers is 58, the number of strips - 1568.

A schematic cross section of the “cold” mRPC is shown in Fig. 3.5.5: it consists of two identical five-gap stacks with an anode strip readout plate in between.

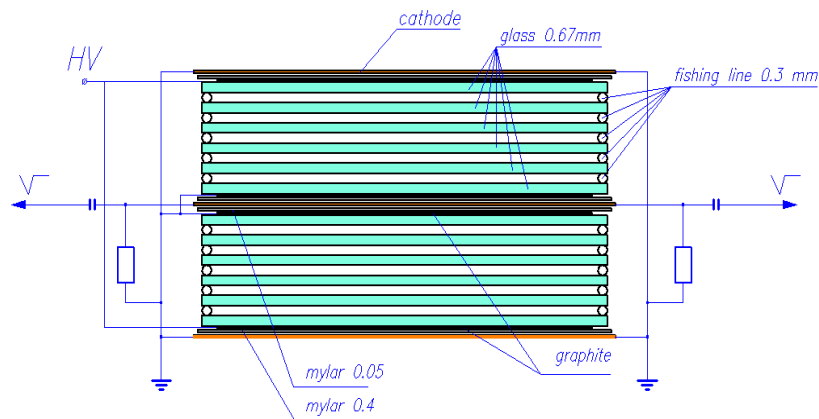

Fig. 3.5.5. Schematic cross-section of the ten-gap mRPC.

Each stack is formed by six glass plates with the bulk resistivity of $2 \times 10^{12} \Omega/\text{cm}$. The anode readout strips plate is a one-sided printed PCB with the thickness of $100 \mu\text{m}$, the thickness of the copper is 35 microns. Signals are taken from both ends of the anode strips. The entire mRPC assembly is put into a gas-tight box.

Heating and thermal stability of “warm” mRPC

In order to provide good time resolution for a high particle rate the “warm” mRPC should be operated at about 40 degrees Celsius. To warm the chamber a special surface heaters were designed. The required temperature inside the “warm” mRPC is achieved with the heaters installed on both sides, top and bottom. The mRPC thermo-stabilization system includes the digital thermometers soldered on the motherboard inside the mRPC box. The thermometers are connected to microcontroller boards, which in turn are connected to a master controller. The master controller

receives temperature setting from the data acquisition computer and reads an actual temperature from the digital thermometers in the mRPC box.

Front-end electronics (FEE) of mRPC

A number of FEE channels for ToF-700 is 3136. As FEE for mRPCs readout the AddOn board developed for the HADES experiment was chosen. The 32-channels FEE module (32RPC board) designed for our mRPCs is based on the NINO chip. The output signal of the NINO amplifier-discriminator is the time-over-threshold pulse whose leading edge provides the time of the hit while its pulse width is proportional to the input signal charge.

The signals from mRPC are delivered to the 32RPC module by 50Ω coaxial cables with the MMCX connectors. Output LVDS signals are transmitted to the digitization module with the DHR-78F sockets. At present, a 64-channel VME time-to-digital converter TDC64VHLE based on the HPTDC chip is used for digitization.

Controls of the power supply, threshold settings, stretch time settings and hysteresis settings of the 32RPC boards are done by a special designed power and control module (PWR&CTRL). The PWR&CTRL module is controlled by the U-40 VME module via a digital SPI interface.

The support of ToF-700 wall

The construction of the wall support is shown in Fig. 3.5.6. To ensure an overlap between active areas of the mRPCs, the chambers should be arranged on the wall in four layers.

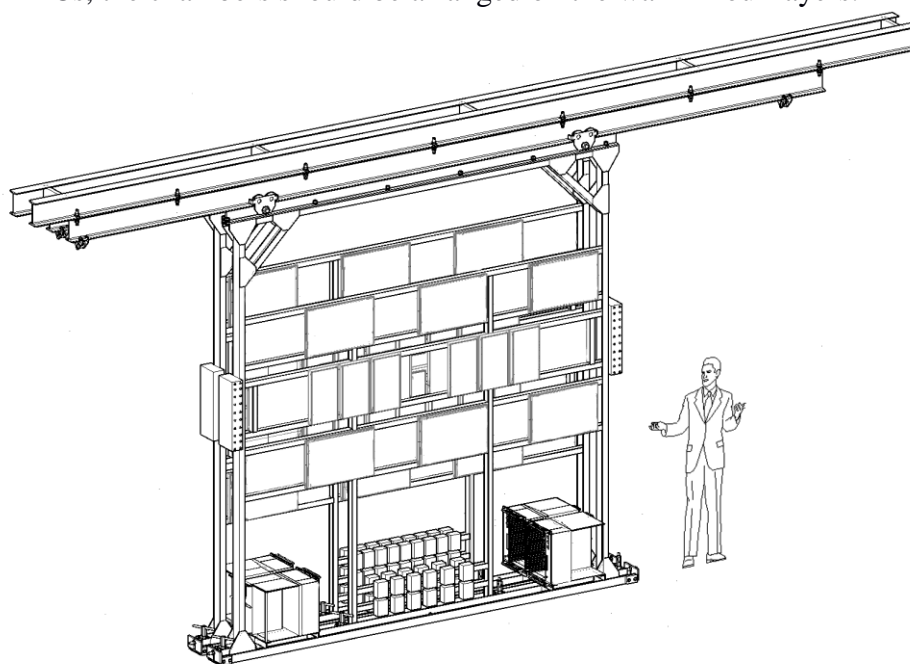

Fig. 3.5.6. The design of the ToF-700 wall (model).

The wall consists of two subwalls. The chambers are located on both sides of the sub walls. Both subwalls can move relative to each other to provide access for installation and maintenance.

ToF-700 data analysis

TOF-700 data analysis software was developed in the BMNROOT package framework. The analysis includes few stages and takes into account: INL (TDC non-linearity) corrections, VME crates Time Stamp differences, time corrections versus the T0 pulse width, time corrections versus the TOF pulse width, equalization of each strip time response for the main time peak. Finally, we use tracks reconstructed in GEM+DCH detectors and ToF-700 time data to reconstruct proton tracks and calculate the time correction for each strip (this correction shifts the reconstructed particle mass to the nominal proton mass). Fig. 3.5.7 - Fig. 3.5.10 illustrate the quality of the fragment separation versus the track momentum, the ToF registration efficiency versus the track coordinate in DCH chamber and the ToF-700 time resolution.

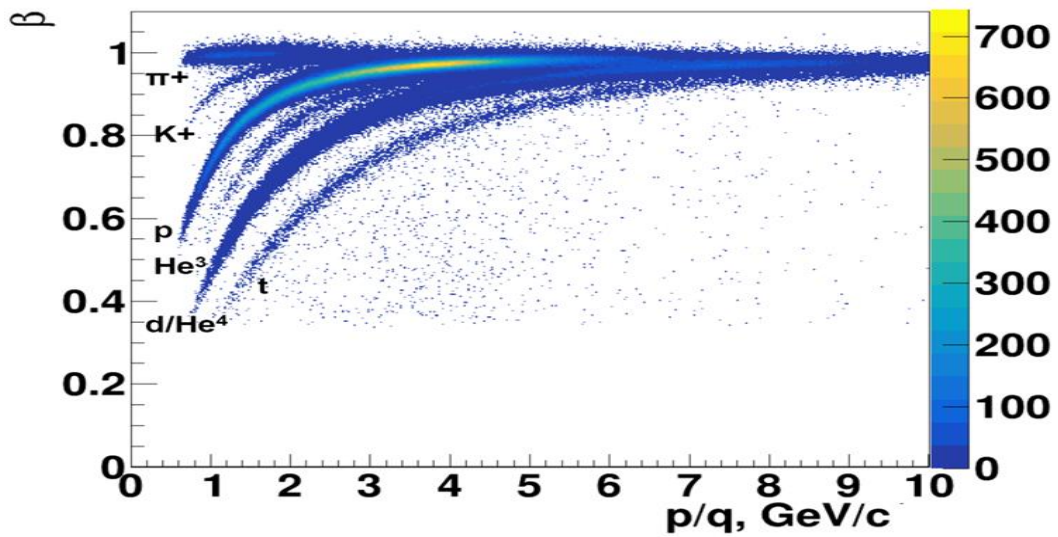

Fig. 3.5.7. Separation of hadrons and nuclear fragments in the plot of the particle $\beta=v/c$ vs momentum.

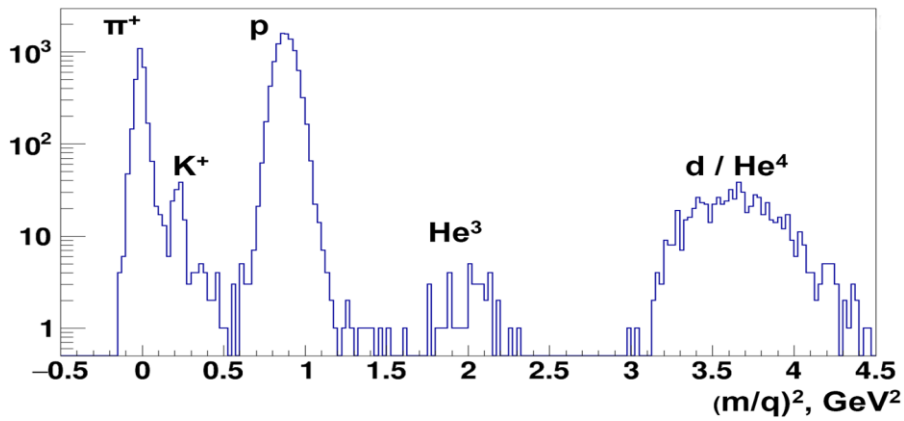

Fig. 3.5.8. Distribution of reconstructed particle mass to charge squared.

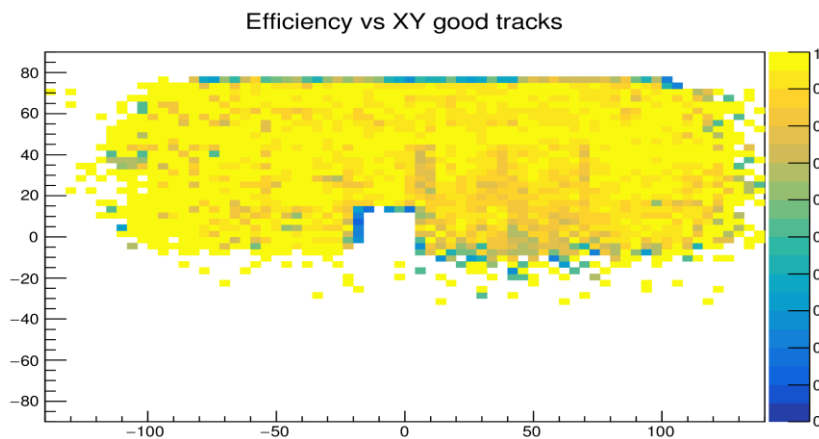

Fig. 3.5.9. ToF-700 registration efficiency vs XY coordinate of tracks reconstructed in the DCH chambers. Only the upper part of the central tracking was available.

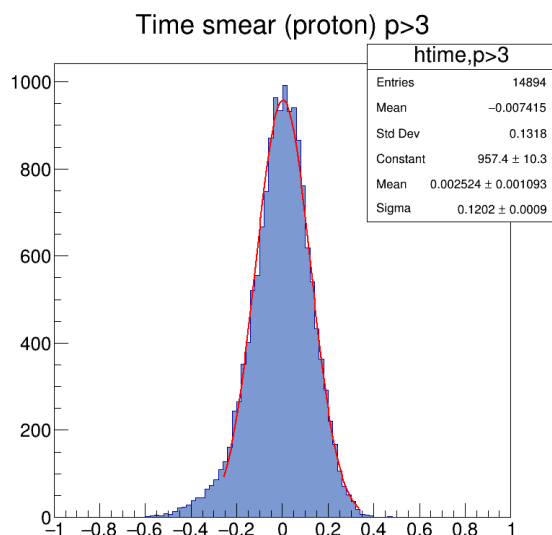

Fig.3.5.10. Time resolution (ns) of the ToF-700+T0 system integrated over all the mRPC detectors.

Details of the ToF-700 mRPC detectors and the measured time resolution and efficiency are described in the TDR document [3.5.2].

References

[3.5.1] http://bmshift.jinr.ru/wiki/lib/exe/fetch.php?media=tdr_tof400_may2017_v1.docx

[3.5.2] http://bmshift.jinr.ru/wiki/lib/exe/fetch.php?media=tdr_tof700_may2017_v1.docx

3.6 Calorimeters

3.6.1 Forward hadron calorimeter FHCAL

A new forward hadron calorimeter (FHCAL) will be served as a Zero Degree Calorimeter (ZDC) at the BM@N setup (Fig.3.1.1). It will be used to measure the centrality and reaction plane orientation in planned heavy ion experiments. In 2020 this calorimeter was completely assembled, including the installation of FEE boards with photodetectors in all calorimeter modules, as well as readout electronics. Photos of the calorimeter installed in the BM@N experimental hall on a mobile platform are shown in Fig. 3.6.1.

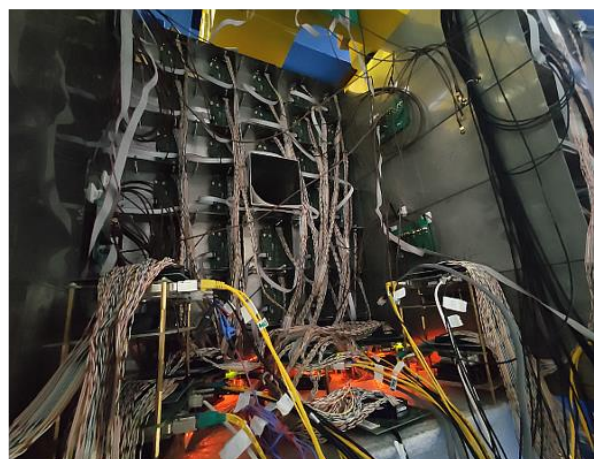

Figure 3.6.1. Photos of new FHCAL calorimeter. Left, front view. Right, rear view of the calorimeter with electronics.

The already constructed calorimeter is positioned at the end of the BM@N setup at a distance 9 m from the target (see Figure 3.6.1, right). The calorimeter has modular structure in the transverse plane and consists of 54 individual modules. The inner part of FHCAL consists of 34 modules with transverse sizes of $15 \times 15 \text{ cm}^2$. There is the beam hole in the center with transverse size $15 \times 15 \text{ cm}^2$. This hole is required to reduce the radiation dose and activation of the calorimeter and to reduce the neutron background at the rear part, where the photodetectors and electronics are located. The inner modules are identical to ones of the forward hadron calorimeters of the MPD experiment at the NICA accelerator complex and have a length equal to 4 nuclear interaction lengths. The outer part consists of twenty modules with transverse dimensions of $20 \times 20 \text{ cm}^2$ and a length equivalent to about 5.6 nuclear interaction lengths. The modules were initially constructed for the CBM hadron calorimeter at the FAIR accelerator complex and will be temporary used in the hadron calorimeter of the BM@N experiment until the commissioning of the CBM experiment. All FHCAL modules have sampling structure. The CBM modules have 60 lead/scintillator layers, while the MPD/NICA modules have 42 similar layers. Each layer consists of 16 mm lead plates and 4 mm scintillator plates. The light from each scintillator plate is transported to the end of modules with WLS-fiber embedded in the groove in the plate. The fibers of each six consecutive scintillator tiles are combined to one optical connector and light from these 6 fibers is read-out with single photodetector (Hamamatsu MPPC with active sensitive area $3 \times 3 \text{ mm}^2$) mounted on front-end electronics plate at the end of the module. Such longitudinal segmentation provides the uniformity of the light collection along the module and high dynamic range of the calorimeter response. The segmentation of modules also allows to perform the FHCAL energy calibration with cosmic muons.

In 2020 the calorimeter was installed at the BM@N, equipped with FEE and readout electronics.. The installation and adjustment of the 54 FEE readout electronics boards were carried out. For data readout, a system of 8 ADC64s2 ADC boards was assembled. Each board can read up to 64 channels of differential signal, all boards have been integrated into the common DAQ of the BM @ N experiment. The communications cable channels from the DAQ rack to the calorimeter and its systems have been renewed. Ethernet cables are laid to all 8 ADC boards, as well as optical cables for transmitting signals from the White Rabbit (WR) system and coaxial cables to provide the ADC boards with trigger logic signals. At the moment a Java code using a package of modules for working with a serial interface is used as a system to control the detector parameters. In the future, it is planned to improve the software part of the DCS calorimeter system and integrate it into the general DCS system of the BM @ N experiment. Commissioning and energy calibration of the FHCAL with cosmic muons was started in 2021.

3.6.2 Fragment quartz hodoscope for FHCAL

The presence of a beam hole in the calorimeter leads to a significant leakage of heavy fragments through this hole and, as a consequence, to a non-monotonic dependence of the deposited energy in the calorimeter on the collisions centrality. To solve this problem, it is proposed to use together with the FHCAL a nuclear fragment hodoscope (FQH), which will measure the charges of heavy fragments. The FQH (Fig.3.6.2, left) consist of 16 quartz plates 160 mm long, 4 mm thickness and 10 mm width. The active area of the hodoscope is $160 \times 160 \text{ mm}^2$. The light from each of the 16 quartz plates is readout from two opposite ends by two pairs of Hamamatsu photodiodes MPRS S12572-015P with an active region size of $3 \times 3 \text{ mm}^2$ and a quantum efficiency of about 20%. The response of an individual hodoscope detector and the homogeneity of its light collection were studied at a test electron beam with an energy of 300 MeV at the FIAN "Pakhra" synchrotron. Fig. 2, right, shows the result of measuring the homogeneity of light collection from each and both ends of the plate.

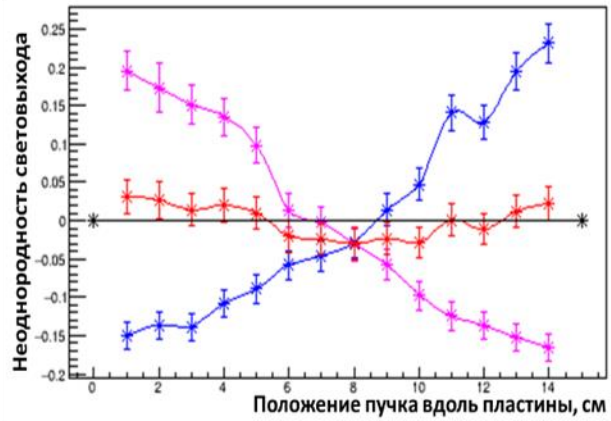
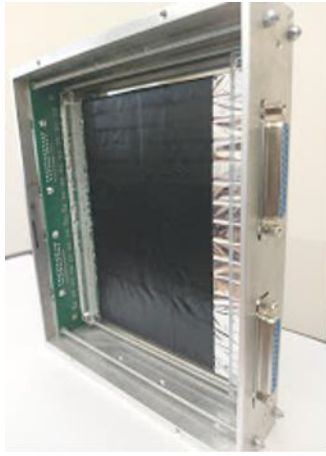

Figure 3.6.2. Left plot: photo of the assembled beam hodoscope. Right plot: inhomogeneity of the light output along the length of the quartz plate. Lines with blue and crimson colors correspond to two pairs of photodiodes located at opposite ends of the plate. The red line corresponds to the inhomogeneity of the light collected and averaged over signals from opposite ends.

The average light output from the two ends of the plate corresponds to about 5 photoelectrons, which makes it possible to reliably detect even particles with a charge $Z = 1$. Since the intensity of the Cherenkov radiation is proportional to the square of the charge, for fragments with $Z = 2$, the signal should already be about 20 photoelectrons. Note that the strong dependence of the signal amplitude on the distance to the photodiode can be used to determine the point of passage of the particle through the hodoscope, which will make it possible to determine the coordinates of the particle. The inhomogeneity of the response does not exceed 5% when the light is measured by pairs of photodiodes from two opposite ends of a quartz plate. To further increase the light output of the quartz detector, it is planned to use in the final assembly of the hodoscope the latest silicon photomultipliers from Hamamatsu (Japan), type S14160-3015PS, with a quantum efficiency of light detection 1.5 times higher than that of the photodiodes used in these tests. Because at the initial stage of the Nuclotron operation beams of light nuclei (carbon) will be used, an additional similar hodoscope with scintillator plates was constructed also.

The FQH will be installed behind the calorimeter and completely cover the calorimeter beam hole. The correlation of the FQH signal amplitude and energy deposition in the FHCAL is shown in Fig.3.6.3 for events simulated with DCM-QGSM model for Au+Au collisions at 4.5 AGeV. Dividing the events into 10 centrality classes are shown here with different colors.

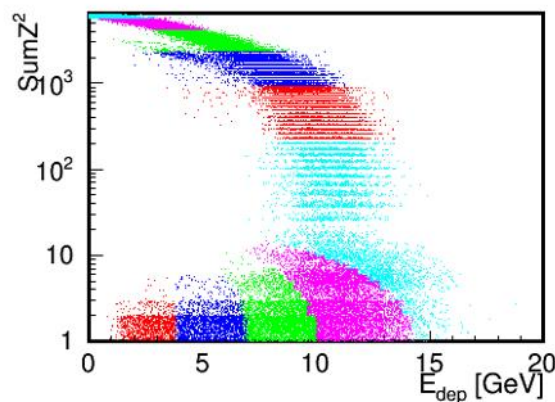

Figure 3.6.3. The correlation of the amplitude of the signal from the FQH and energy deposition in the FHCAL.

As it is seen from Fig.3.6.3, the most centrality classes of events can be selected already on trigger level with the use of the cut on the hodoscope signal amplitude and the FHCAL energy deposition. The FQH and FHCAL are ready for first beam runs after finishing the BM@N upgrade.

3.6.3 Calibration of the calorimeter modules with cosmic muons

The longitudinal and transverse segmentation of the new hadron calorimeter makes it possible to calibrate the FHCAL using cosmic muons, since the absence of the muon beams at the Nuclotron accelerator does not allow calibration at the beam. The electronics of the data acquisition system (ADC) -allows to collect data from cosmic muons by both self-trigger and using a trigger from an analog adder. Aggregate signals from the sections of all modules are collected, summed up and fed to the discriminator. By adjusting the discrimination threshold it is possible to set the required minimum number of triggered sections for accurate determination of the muon track that has passed through the calorimeter. To reconstruct muon tracks, a special algorithm was developed for searching the tracks in the 3D space in the calorimeter sections. An example of the reconstructed muon track is shown in Fig. 3.6.4, left.

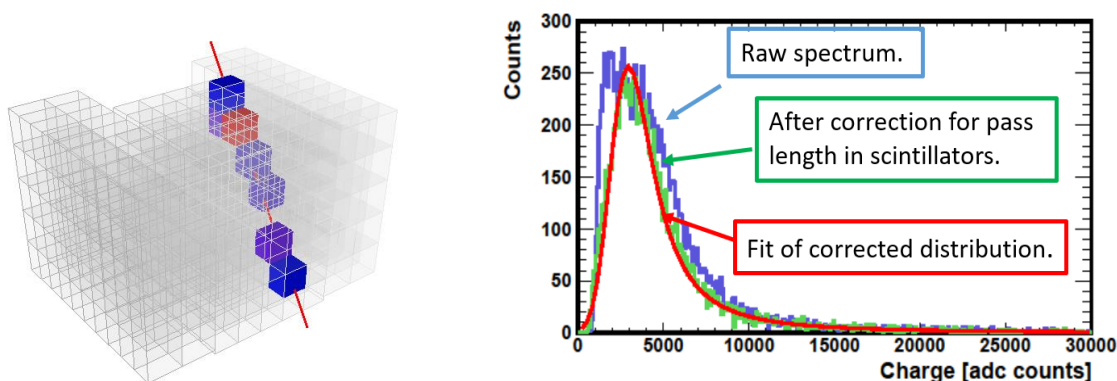

Figure 3.6.4 Left plot: An example of a 3D view of a muon track in FHCAL. Right plot: The result of the track length correction in one of the sections of the FHCAL module. The blue curve shows the muon spectrum before the correction, the green curve shows the muon spectrum after the correction of the track length. The corrected spectrum is fitted by the Landau and Gaussian function (langaus, red curve).

The corrected spectrum fits much better with the standard convolution function of the Landau and Gaussian function (shown in red). With this approach the calibration constants for all calorimeter sections can be determined. In 2021 all FHCAL modules will be calibrated using this approach.

3.6.4 Development of a new approach to centrality determination by FHCAL

Due to the presence of a beam hole in the center of calorimeter a certain part of the spectators energy because the most of the heavy fragments escaping through the hole. In this case the dependence of the total energy deposition in the calorimeter on the impact parameter becomes non-monotonic, making the task of determining the centrality more difficult. One of the approach is to measure centrality with the use of the beam quartz hodoscope in addition to the FHCAL as was shown in the section 3.6.2. However, the total energy deposition in the calorimeter is not the only observable in the event. The modular structure of the calorimeters makes it possible to use the spatial distribution of energy in separate modules of the calorimeter. The deposited energies in all modules, forming together the so-called "energy surface", allow, within certain limits, to solve the centrality determination problem. The responses of the hadron calorimeter modules can be used as an array of values, which makes it possible to apply machine learning (ML) methods to the centrality problem using an algorithm similar to image analysis. Machine learning techniques have proven themselves well in pattern recognition and image classification. Application of machine learning methods to determine centrality classes allows using a larger amount of available information from hadron calorimeter comparing to existing

approach, making it possible to determine centrality over the entire range of centrality. To determine collision centrality, two machine learning approaches have been developed, the supervised approach and the unsupervised approach. Both ML approaches were tested on the BM@N simulation data of AuAu collision at energy of 4.5 AGeV with DCM-QGSM. The comparison of average value of the impact parameter and the impact parameter resolution as function of centrality classes obtained with ML supervisor approach as well as a from correlation between energy deposition in the FHCAL and Z^2 in the FQH are shown in the figure 3.6.5. The results for the two approaches are in good agreement and will be used in the analysis of new experimental data at the BM@N.

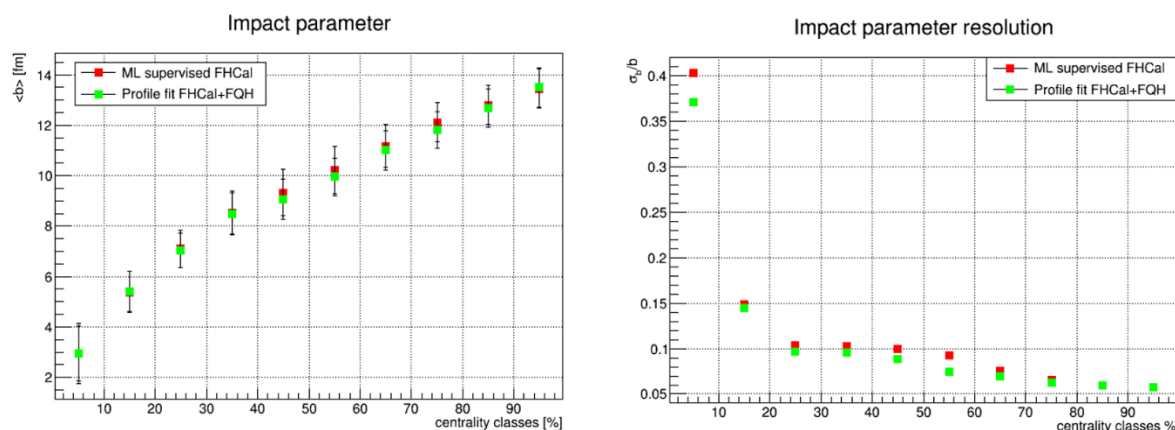

Figure 3.6.5. The distributions of mean value of impact parameter and impact parameter resolution as function of centrality (left and right, correspondingly). Green points – dependencies obtained from correlation between FHCAL energy deposition and FQH amplitude. Red points – distributions obtained from energy depositions in FHCAL modules with supervised ML approach.

3.6.5 Upgrade of the forward calorimeter system

It is proposed to extend forward calorimeter system, which include now FHCAL and FQH, and add in addition the detector ScWall (Scintillator Wall) to have the possibility to measure not only the centrality and reaction plane in heavy ion collisions but to measure fragmentation of nucleus. The new experimental fragmentation data for heavy ions collisions are needed to validate fragmentation models used in event generators to simulate the BM@N experiment as well as MPD and CBM experiments. The BM@N is the most suitable experiment for the study of fragmentation in heavy ion collisions because the BM@N has powerful analyzing dipole magnet deflects the significantly charged components of the spectators and partially separates them from the neutron spectators. The separate measurements of charged and neutron spectators allow to study the mechanisms of fragmentation and the equation of state of nuclear matter. It is proposed that the measurements of the heavy charged fragments and proton spectators will be performed with the FQH and ScWall correspondingly, while the modified forward hadron calorimeter will be used to measure the neutron spectators.

According to the simulations (see Fig. 3.6.6, top) charged fragments distributions are quite well separated from neutron spectator's distribution on the FHCAL front plane. The simulation has been done for the reaction Au+Au at 4.5A GeV with the DCM-SMM generator in bmnroot framework. Considering the spatial fragments distributions, it is proposed to upgrade the present BM@N forward calorimeter system consisting of FHCAL and FQH. First of all, it is proposed to transform the FHCAL into the ZDC to measure neutron projectile spectators. The ZDC can be assembled from 36 modules of FHCAL central part. To measure charged fragments the new ScWall with already existing FQH placed behind the beam hole in the ScWall is proposed to use. The ScWall will consist of 36 scintillator detectors with transverse sizes $7.5 \times 7.5 \text{ cm}^2$ surrounding the beam hole and 134 outer cells with transverse sizes $15 \times 15 \text{ cm}^2$. The light from each scintillator detector will be collected by WLS glued in the groove in the scintillator plate and will be detected with 1mm^2 Hamamatsu MPPC. The relative position of the ZDC, ScWall and FQH is shown in Fig.3.6.6,

down. There is overlapping of the ZDC and ScWall, which is needed to reject charged spectators entering the ZDC.

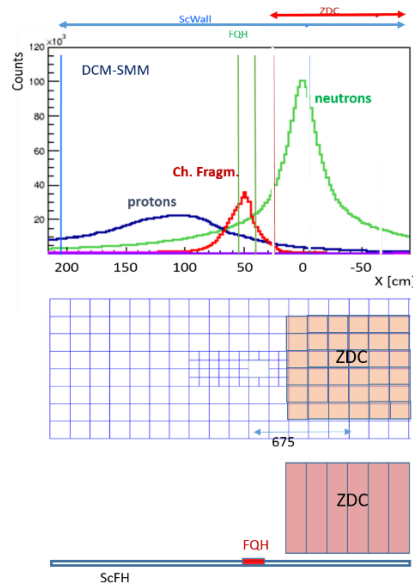

Figure 3.6.6. Simulated fragments distributions along horizontal axis at the plane perpendicular to the beam line at 9 m from the target (at the front of the ZDC), upper figure. In the middle and down figures the schematic top and front view of forward detectors (ZDC, ScWall and FQH) are shown.

EP resolution

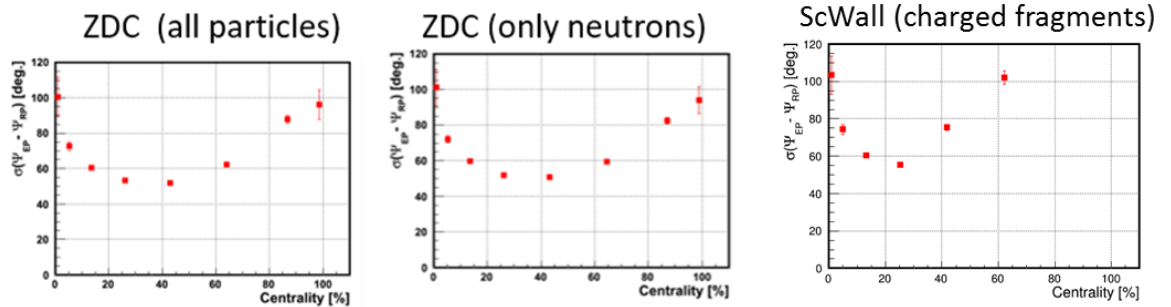

Figure 3.6.7. Event plane resolution (in degrees) measured as a function of the event centrality using all particles, neutrons and charged fragments hitting the ZDC and ScWall detectors

The new forward calorimeter system including the ZDC, FQH and ScWall will be able to measure the fragmentation, centrality and reaction plane in heavy ion reactions. It was shown in the simulation that such detector system will significantly improve the centrality resolution for semicentral events (Fig.3.6.5). The event plane resolution measured with all particles, neutrons and charged fragments hitting the ZDC and ScWall detectors is given in Fig.3.6.7.

It is planned that the development, construction of the ScWall will be performed during 2021-2022 and commissioning of new forward calorimeter system will be done in 2022 and full forward calorimeter system will be used in the BM@N heavy ion physics experiments.

3.6.6 Electro-magnetic calorimeter ECAL

The purpose of the electro-magnetic calorimeter is to study processes with electro-magnetic probes (γ , e^\pm) in the final state. The physics program of the BM@N experiment with the electro-magnetic calorimeter includes the following studies:

1. Study of known resonances and search for new resonances decaying into two γ quanta
2. Study of the yield excess of η^0 -mesons in nucleus-nucleus interactions

3. Study of gamma femtometry – two photon interference
4. Study of soft photon spectra at photon energies below 50 MeV, where the yield of γ quanta exceeds in $\sim 4 - 8$ times the theoretical expectations
5. Search for the correlation between the phenomena of pion condensation and abnormal soft photons

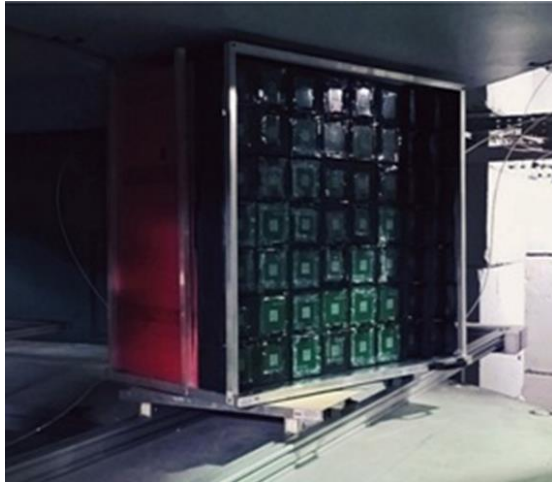

The detailed justification of the BM@N physics program with the electro-magnetic calorimeter is given in the document (in Russian) [3.6.1]. The available modules of the MPD ECAL calorimeter will be installed behind the DCH chambers and ToF-700 wall already in 2016 to serve as an electro-magnetic calorimeter in the BM@N experiment. The description of the MPD ECAL, the energy resolution measured in the beam tests are given in the document [3.6.2].

[3.6.1]

http://bmnshift.jinr.ru/wiki/lib/exe/fetch.php?media=proposal_emc_bmn_16_prelim_040316.docx

[3.6.2] http://bmnshift.jinr.ru/wiki/lib/exe/fetch.php?media=tdr_ecal_v0_13.pdf

3.7 Trigger system and beam detectors

3.7.1 Trigger detectors

A system of trigger detectors shown in Fig. 3.7.1 consists of a set of scintillation and Cherenkov beam counters BC1, BC2(T0) and VC multiplicity detectors in the target area BD and SiD; target area multichannel detectors – a scintillation barrel detector BD and a silicon detector SiD; two forward detectors – a detector of charged nuclear fragments of beam ion FD and a forward hadron calorimeter FHCal.

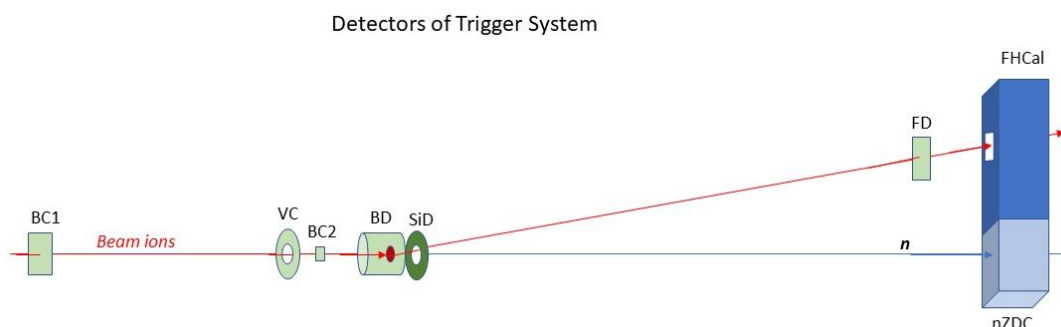

Fig. 3.7.1. A schematic view of trigger detectors of BM@N setup.

The list of physics triggers with corresponding logic is given below.

Trigger type	Trigger logic
Beam Trigger (BT)	$BT = BC1 * VC_{veto} * BC2$
No Interaction Trigger (NIT)	$NIT = BT * FD * nZDC_{veto}$
Min. Bias Trigger (MBT)	$MBT = BT * FD_{veto} * nZDC$
Collision Centrality Trigger (CCT)	$CCT = MBT * BD * SiD$

The active elements of beam detectors are placed in the vacuum beam pipe upstream of the target. The BC1 is based on BC400B scintillator $100 \times 100 \times 0.25 \text{ mm}^3$ viewed by two PMTs Hamamatsu R2490-07. The VC is based on the same type of PMTs and a scintillator with diameter of 100 mm and 27-mm diam. hole for beam ions.

The BC2 plays a role of **T0 detector** with a pico-second time resolution and it is used as start detector for TOF measurements. Basic requirements to this detector are: (i) the time resolution better than 50 ps; (ii) ability to work in beams with high intensity up to 10^6 ions/s; (iii) minimal material in the beam line; (iv) high radiation hardness. Two types of radiators are used for registration of beam ions: a thin scintillator BC400B $30 \times 30 \times 0.15 \text{ mm}^3$ for light nuclei and a thin Cherenkov radiator from optical quartz $40 \times 40 \times 0.20 \text{ mm}^3$ for heavy nuclei. A scheme of the BC2 is shown in Fig. 3.7.2a. Scintillation (or Cherenkov) photons are collected to two MCP-PMT XPM85112/A1-Q400 (Photonis), which provide excellent timing and they are able to work in a strong magnetic field. This is important, since the detector should be placed close to the target inside the analyzing magnet of the BM@N.

Active area of the **Barrel detector** has cylindrical shape with dia. 90 mm. It consists of 40 scintillation strips $150 \times 7 \times 7 \text{ mm}^3$ made of plastic BC418. Each strip is wrapped by aluminum mylar and on one end is connected to a photosensor SiPM Micro FC-60035-SMT, $6 \times 6 \text{ mm}^2$ (SensL). Signals from FEE of the BD are sent to the input of the trigger unit T0U. A view of the detector is shown in Fig. 3.7.2b. The BM@N target is placed inside the BD with position of 40 mm upstream from the end of the BD strips. A lead absorber of δ -electrons produced in the target consists of inner cylinder with thickness of 3 mm and half of disc with thickness of 5 mm and inner and outer radii 40 and 300 mm respectively placed outside of the BM@N acceptance. This geometry of the absorber is the result of background study with MC simulation and this shield provide detector operation with rather small contribution from δ -electrons to the BD response.

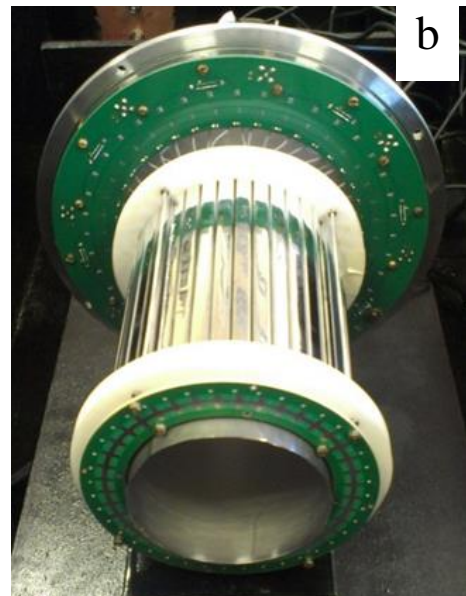
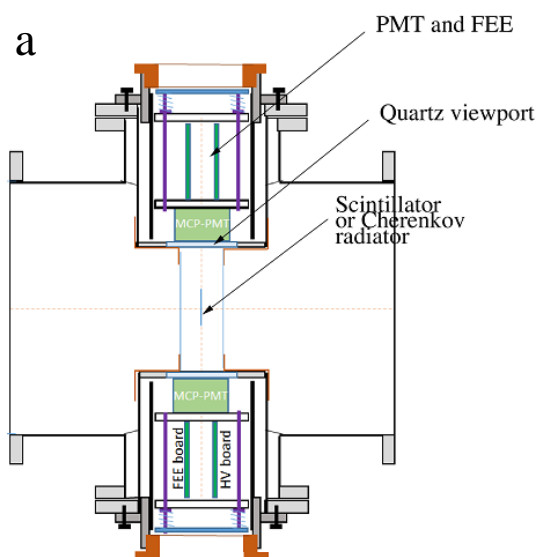

Fig. 3.7.2. (a) The T0 detector design and (b) a view of BD detector.

The forward angle region is covered by the **silicon detector SiD** which is located downstream from the target at the distance of 120 mm. Signals from the detector front-end electronics are sent to a special module Si-Unit, which determines how many SiD channels had hits in the event. This information is passed to the trigger unit T0U, where the number of fired channels is compared to a preset trigger threshold. Multiplicity trigger coordinate plane is based on 2 symmetric half-planes, which simplify assembling process around installed beam pipe. General view of these half-planes with read-out boards is shown in Fig. 3.7.3. Each of coordinate half-planes consists of 4 detectors 525 μ thickness (total number of strips is 32) with 8 strips located at an angle with an interval of 5.6° and an isosceles trapezoid in shape (45°). The inner diameter of multiplicity detector is 51 mm and the outer diameter of the circumscribed circle – 186 mm. Trapezoid detectors for the coordinate plane of the multiplicity trigger have been developed and manufactured by RIMST (Zelenograd).

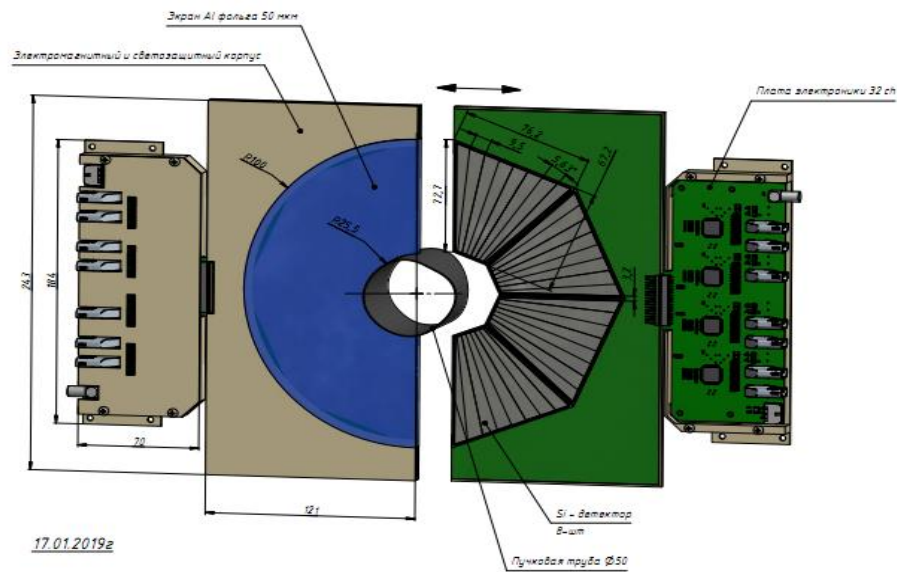

Fig. 3.7.3. The general view of trigger SiD: 8 silicon strip trapezoid detectors and 2 FEE boards.

The **forward hadron calorimeter FHCAL** is described in detail in the corresponding chapter. Here we consider the FHCAL only in view of potentially useful integration of this detector in the trigger system. A special electronics module provides a fast analog pulse for the trigger module T0U. This pulse is the sum of pulse heights of the FHCAL modules.

The **nuclear fragment Cherenkov detector FD** has a sensitive area of $160 \times 160 \text{ mm}^2$ and it is based on four quartz plates $160 \times 40 \times 6 \text{ mm}^3$ in dimension each viewed from both ends by a set of four photosensors SiPM MicroFJ-60035-TSV (SensL) with active area of $6 \times 6 \text{ mm}^2$. The detector is located behind of the beam hole of the calorimeter FHCAL. The detector response is proportional to the sum of fragment charges squared and the pulse is fed to the trigger unit T0U.

The **trigger performance** was studied by MC simulation based on QGSM – GEANT4 code. The obtained results for the main trigger detectors BD, SiD, FD and FHCAL are shown in Fig. 3.7.4 – 3.7.6 for collisions of 4A GeV Au ions with 300- μm Au target. It is clearly seen that the set of target area detectors BD + SiD provides effective triggering on central and semi-peripheral collisions and that the choice of thresholds in the multiplicity detectors helps to suppress the background from δ -electrons produced by beam ions passing through the target. The set of forward detectors FD + FHCAL provides additional capability for setting the Min. Bias trigger by selecting interaction events in an even wider range of centrality.

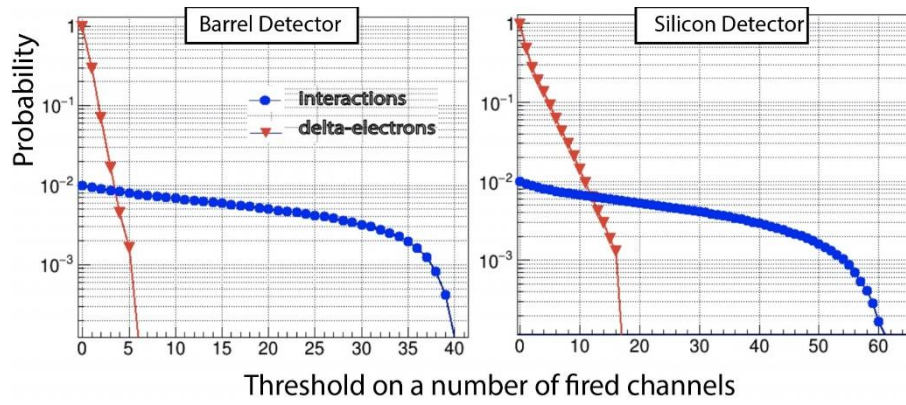

Fig. 3.7.4. The probability of trigger generation by secondary particles of Au + Au interaction (the blue points) and by delta-electrons (the red points) as a function of fired channels for BD and SiD.

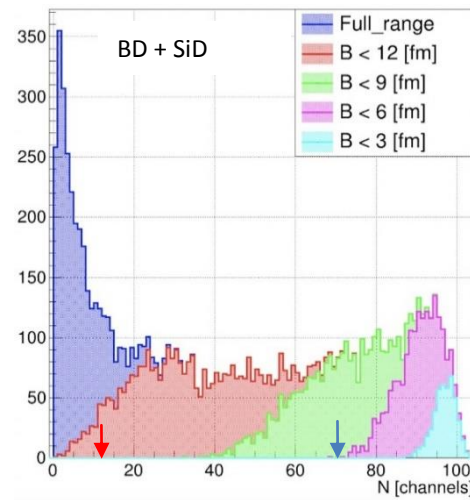

Fig. 3.7.5. The multiplicity of fired channels of BD and SiD for Au + Au collisions at 4 A GeV: the red arrow – the minimal threshold above delta-electron background, the blue arrow – the threshold for selection of central collisions.

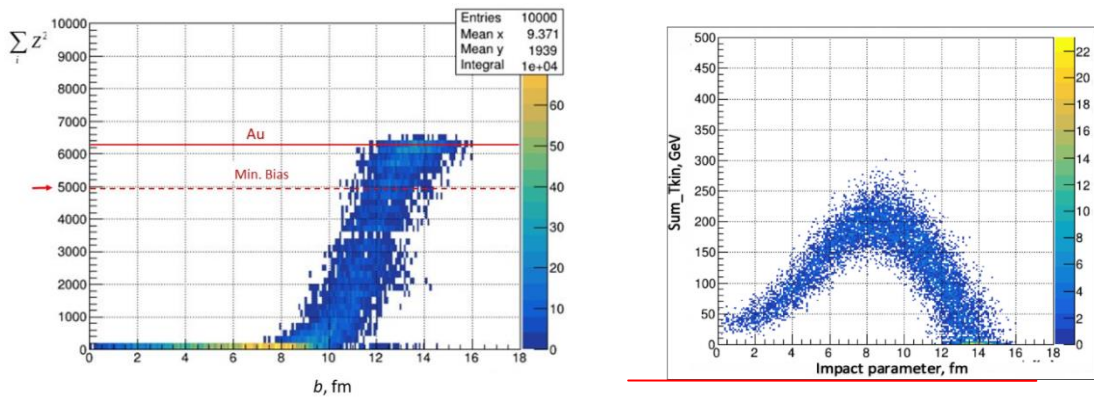

Fig. 3.7.6. The response of the FD to the nuclear fragments (left) and the response of the FHCAL (right) as a function of the impact parameter in Au + Au collisions at 4 A GeV.

Estimation of interaction of Au ions with beam line materials

#	Beam line material	Thickness (mm)	Probability (%)
Upstream materials			
1	BC1 scintillator	0.25	0.6
2	1 st Si detector (see 3.7.3)	0.175	0.36
3	2 nd Si detector (see 3.7.3)	0.175	0.36
4	3 rd Si detector (see 3.7.3)	0.175	0.36
5	BC2 quartz	0.2	0.447
	Sum		2.13
6	Au target	0.3 (0.45)	1.34 (2.01)
Downstream materials			
7	Al foil (entrance window)	0.1	0.24
8	Air	60	0.105
9	FD quartz	1	2.23
	Sum		2.58

Method of background interaction suppression

1. Suppression of upstream interactions by selection of events with high pulse heights (closed to Au) in BC2.
2. Suppression of downstream interactions by selection of events with pulse height above a threshold in nZDC (neutron part of FHCAL).

3.7.2 Trigger electronics

The trigger electronics is divided into two parts A and B. A scheme of the trigger electronics system is shown in Fig. 3.7.7. The part A is realized as a trigger module T0U based on FPGA. The T0U processes input pulses from the trigger detectors and provides physics triggers in correspondence with programmed logic. The input pulses of the T0U module are analog pulses from BC1, BC2, VC, FD and FHCAL plus LVDS pulses from 40 channels of BD and 64 channels of SiD. The module provides fast coincidence of pulses and calculation of multiplicities of fired channels of BD and SiD. A particular physics trigger is generated, if the response of all detectors participating in its logic satisfies the selection criteria, i.e. all pulse heights and hit multiplicities exceed the thresholds preset for this trigger.

The pulses of the physics triggers are fed to inputs of electronics of the part B. The tasks of this part of electronics includes formation of the final BM@N physics trigger from the mixture of triggers with corresponding reduction factors, and generation of special triggers out of spill for calibration of the detectors. In addition, this electronics makes Before/After protection using pulses from the first beam counter BC1. The pulses of trigger detectors are fed to the readout electronics modules TDC, TQDC and Scalers for online monitoring and offline analysis.

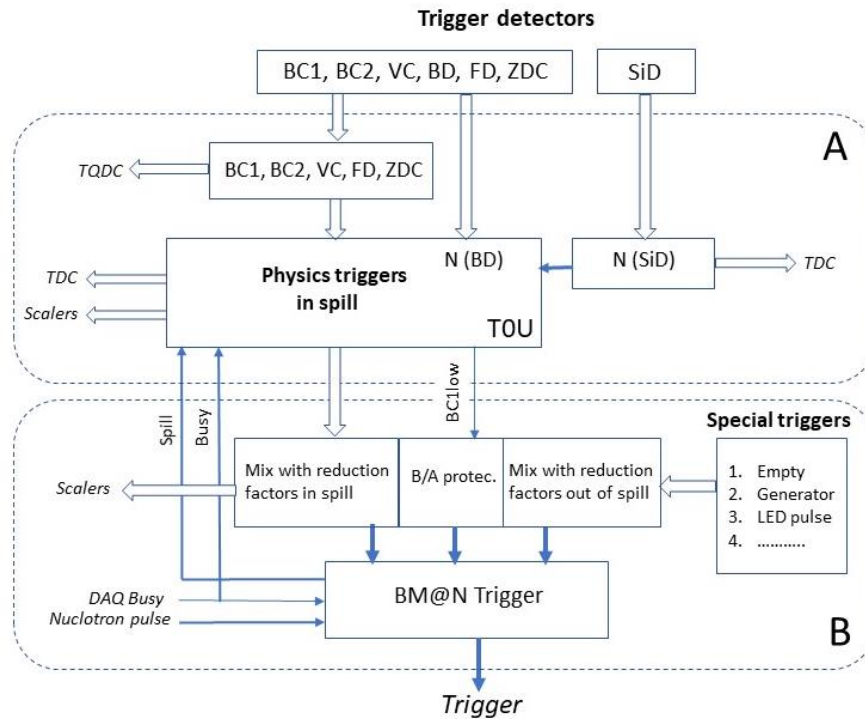

Fig.3.7.7. A scheme of trigger electronics.

3.7.3 Silicon beam tracker

Three beam tracker coordinate planes have been designed to determine the coordinates of incident beam ions. The beam tracker planes are placed inside the beam pipe before the target (Fig. 3.7.8). Each plane is based on Double-sided Silicon Strip Detector (DSSD) with the size of $63 \times 63 \times 0.175 \text{ mm}^3$ consisting of $128p+/128n+$ strips with a 90° stereo angle between strips (Fig. 3.7.9). Due to radiation damage in detectors by light and heavy ions, thin float-zone silicon wafers ($175 \mu\text{m}$) have been chosen for manufacturing DSSD to get low radiation damage and minimize amount of material to reduce multiple-scattering and beam interactions with the detectors.

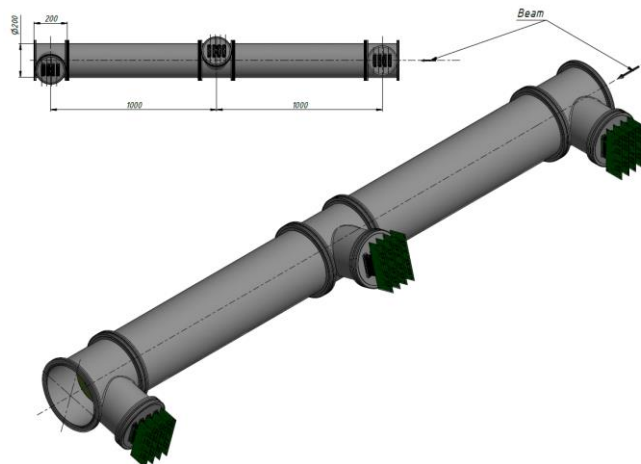

Fig 3.7.8. Beam pipe section with the beam tracker modules

Special requirements for FEE ASIC are ability to register large signal from heavy ions and to sustain high event rate, i.e. wide dynamic range (up to 20 pC), short peaking time (less than 200 ns) for pile-up rejection, at least 64 channels per chip, sample-and-hold from external trigger and multiplexed output (for compatibility with the Si data format transmitted to the BM@N DAQ system). The ASIC VATA64-HDR16 of IDEAS (Norway) was chosen as the closest in parameters

and requirements. Based on this ASIC the FEE board of the beam tracker has been developed. The FEE board is installed on the vacuum station flange incorporated in the beam pipe structure and connected via vacuum multi-pin connectors with 256 detector strips.

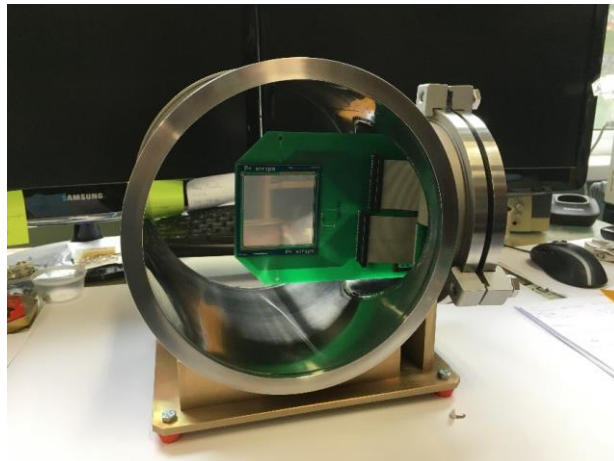

Fig 3.7.9. Beam tracker module inside the beam pipe section

3.7.4 Silicon beam profilometers

Two beam profilometer planes have been developed for beam tuning during the BM@N runs. The beam profilometer is based on DSSD and placed inside the beam pipe (Fig. 3.7.10).

The distance between two planes is approximately 3m. The second plane is placed at 40 cm before the target in front of the beam counter (BC2). The silicon detector has 32p+/32n+ strips with 90° stereo angle between strips and 60x60 mm² size which is sufficient to fit the beam size on the sensitive area of detector.

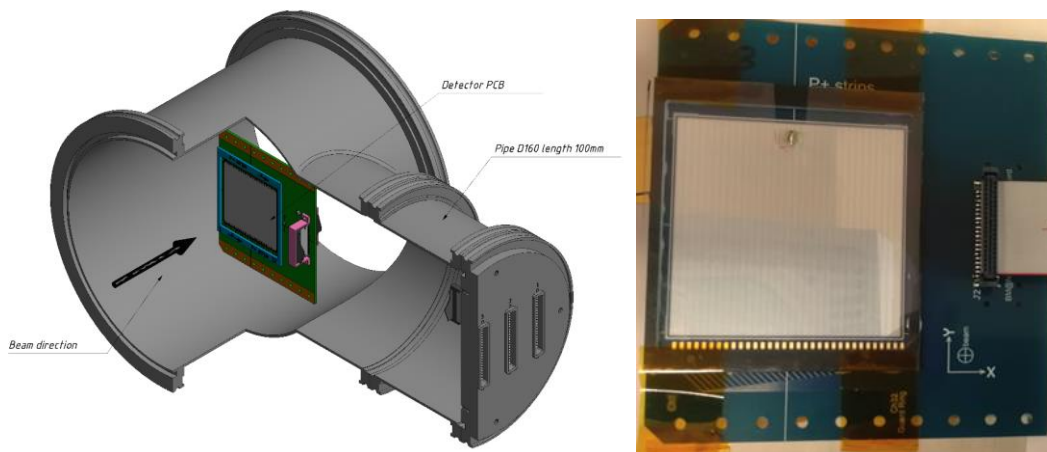

Fig 3.7.10 Detector plane inside the beam pipe (left). Beam profilometer detector plane (right)

Because of the requirement for a wide input charge range two versions of front-end electronics (FEE) for the beam profilometer will be used for light and heavy ions. The front-end electronics is based on VA163 chips (dynamic range is $\pm 750fC$) for light ions and VA32HDR11 chip ($-35pC \div +25pC$) for heavy ions. All ASICs are manufactured by IDEAS, Norway. Each chip has 32 inputs of charge sensitive pre-amplifiers (CSA), all pre-amplifier outputs are connected to TA32cg2 (32 channel front-end fast triggering ASIC) to form a self-trigger signal for an external system. Each VA163 pre-amplifier output is connected to a shaper (with 500 ns shaping time). The pulse amplitude from all shaper outputs could be multiplexed sequentially to the analogue output buffer by readout diagram.

The mechanical construction of profilometer planes could be automatic removal from beam zone to a special branch pipe after beam tuning (Fig.3.7.11).

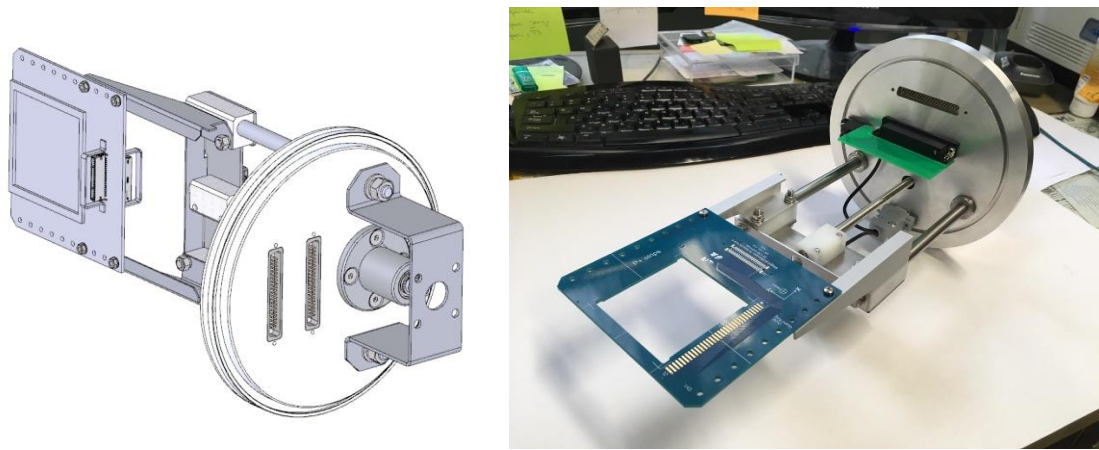

Fig 3.7.11. Beam profilometer mechanical support: 3D model (left), photo (right)

3.8. BM@N DAQ system and computing

The core function of the DAQ system is realization of data transfer from the detector to the storage system. It includes the data flow from readout electronics to the First Level Processor (FLP) fabric, to the Event Building (EB) and to the Storage System. Main DAQ components are data transfer networks, data processing servers, online storage system, Readout electronics interface, Clock and Time Synchronization (Timing) System and Trigger Distribution.

DAQ system at BM@N consist of 3 large parts:

- Electronic modules, developed by DAQ group, which include DAQ electronics, digitizing modules for all detectors at BM@N, detector control modules, front-end electronics and specific modules;
- Network infrastructure includes White Rabbit Network, Data Transfer Network, Slow Control Network and First Level Processors (FLP).
- Data processing, management, analyzing, utility and control software.

3.8.1. Main electronics modules

There are two large family of digitizing modules: time to digital converters (TDC) and waveform digitizers (ADC).

TDCs are used at TOF400, TOF700, DCH and FFD detectors and ADCs – at ECAL, FHCAL, GEM, STS and CSC detectors.

TDC72VHL and TDC64VHLE is 72-channels and 64-channels VME64x modules with 25 ps resolution. TDC64V is 64-channels VME64x module with 100 ps resolution.

ADC64VE and ADC64S2 are 64-channels 62.5 MSPS waveform digitizers.

There will be used about 100 ADC and 150 TDC modules in the final configuration.

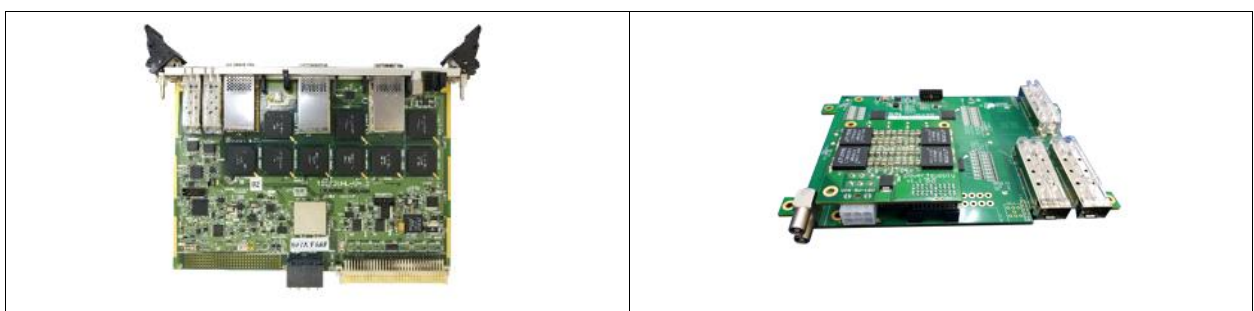
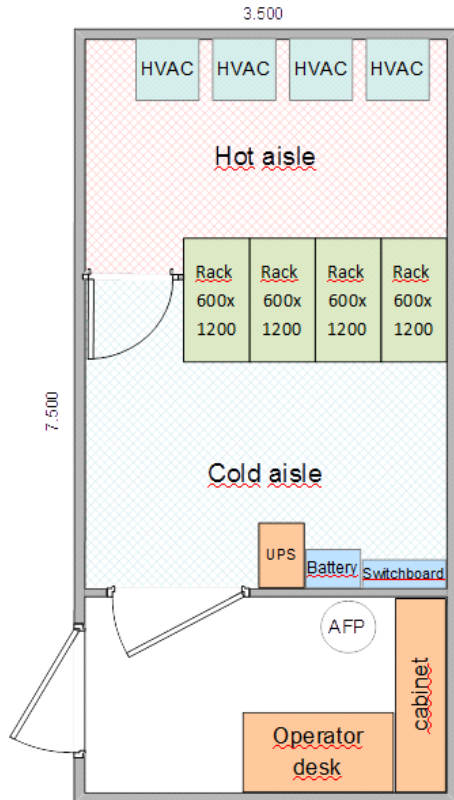

Fig. 3.8.1.1. TDC72VHL (left) and ADC64S2 (right)

3.8.2. Network infrastructure

Major part of network infrastructure allocated in Modular Data Center (MDC) (figure 3.8.2.1). Experimental area connected to MDC through multiple fiber-optic links. These links are used for hardware control and obtained data transfer to BM@N storage system.



Specifications	
Input power	50 kW
IT power	24 kW (N+1) / 30 kW max
Rack count	4 racks
Redundancy	N+1 (UPS, HVAC)
Battery backup	8 minutes
Rack size	600 x 1200 x 42U

Stage-1 Equipment	Rack Units
Passive network	16
Active network (switches, controllers)	18
Infrastructure nodes	4
FLP, Event Builder nodes	44
Transient Flash Storage	13
Message Logging and Search	5
Reserve (Stage-2)	68

Fig. 3.8.2.1. Modular Data Center specifications.

The BM@N Storage System has two stages: the Transient Data Storage (TDS) 285 TB and Permanent Data Storage (PDS) 1.8 PB. It utilizes a two-tier software architecture and data migration from TDS and PDS is transparent to the user. The TDS performs the temporary storage of raw data produced by Event Builder system. The data are recorded to the TDS during data-taking phase of BM@N and is continuously migrated to permanent storage.

White Rabbit network provides sub-nanosecond accuracy and picoseconds precision of synchronization for large distributed systems. The time reference is provided by GPS/GLONASS receiver and backup precision frequency reference (Cesium or Rubidium clock).

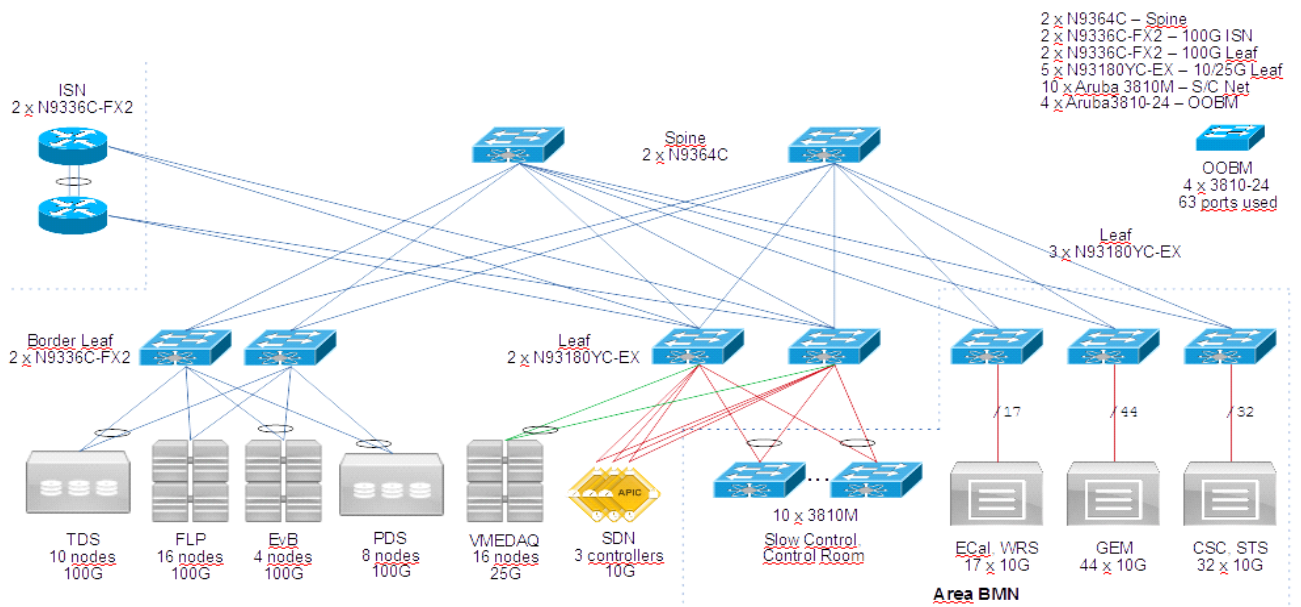

Fig. 3.8.2.2. BM@N DAQ Network

3.8.3. DAQ Software

DAQ software consists of three functional parts: hardware control, event building and run management. All settings of all programs and complete Run setting are stored in Mongo database.

Readout board controls

The set of this programs performs hardware configuration and transition of readout data to event builders.

Event builder

The task of this programs set is to collect data from several client programs (mstream program or another event builder), separate event blocks in every data flow, combines them together per events and further retransmits or writes to the file as united data block.

Run management

These programs performs run preparation, start, stop and correct run flow (event synchronization, correct data acquisition, hardware status monitoring etc.)

Modular structure is common property of all DAQ software. It makes possible to easily add new subsystem or exclude existing from Run. Such excluded subsystems can work autonomous in parallel with main system.

The slow control parameters of the detectors are stored via the TANGO interface into a data base. The access to the data base is performed using the software interface developed within the BmnRoot software.

3.9 BmnRoot framework and analysis software

At present, the activities on the detector and beam line construction are complemented with intensive Monte Carlo simulation studies for optimization of the detector setup. Monte-Carlo simulations aimed in the optimization of the BM@N design have been performed with a sample of generated Au+Au events and lighter ion interactions. For these simulations a dedicated BmnRoot framework intended to process both simulated and obtained experimental data is developed. The same software package is used to define the experimental setup, provides detector performance studies, event simulation, and development of algorithms to be used for digitization, reconstruction and physics analysis of particle collision events with a fixed target. BmnRoot is implemented on

the basis of the CERN ROOT 6 environment and object-oriented FairRoot framework of the FAIR collaboration at GSI Institute. BmnRoot is available in the JINR GitLab repository providing GIT Continuous Integration tests to ensure software correctness.

To obtain realistic detector responses very detailed geometrical description of each of the subdetectors has been performed. To define the detector geometries, the ROOT format in the form of a tree containing basic geometric volumes is mainly used in BmnRoot. A complementary XML file including detailed parameters of the detector structure, which are required for realistic simulation, digitization, hit reconstruction, is used. To study physics feasibilities of the experiment, BmnRoot supports a wide list of Monte-Carlo event generators with the proper physics effects, such as DCM-QGSM and DCM-SMM to provide realistic particle and energy distributions, investigate physics effects and to simulate different versions of the setup. Particle propagation through the detectors in simulation is performed using Geant 3 or Geant 4. The Fluka transport package is used to estimate radiation doses and neutron fluxes in the BM@N experimental zone.

Event data processing in the BmnRoot framework are realized via ROOT macros, which perform simulation, digitization, reconstruction and various physics analyses. In turn, their inner tasks, such as detector response functions, tracking, particle identification and others, are implemented as a chain of FairRun Manager Tasks. The steps of event data processing in the BmnRoot framework are shown in Figure 3.9.1.

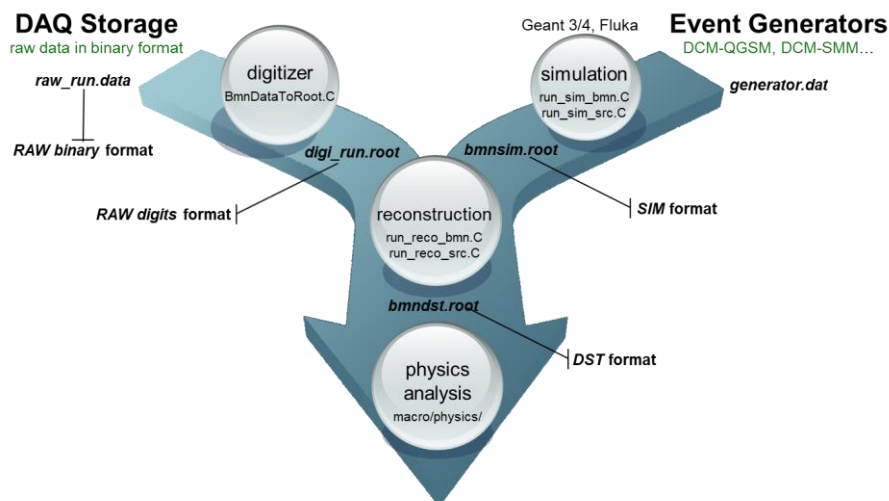

Fig. 3.9.1. Event data processing in the BmnRoot framework

Raw experimental data obtained from DAQ in a binary format are digitized and converted into the ROOT format by a digitizer (ROOT digitizing macro). The obtained digit file contains a digit run header and hierarchical ROOT tree with event headers and digits grouped by events for all the detectors. Two reconstruction macros (main BM@N and SRC programs) use developed reconstruction algorithms and restores the information on produced particles registered by the detectors, their momenta, types, tracks, and other kinematic parameters. The restored information is saved in a DST (data summary tape) file containing detailed output of the reconstruction, such as ROOT branches with hits, particle tracks, primary vertex and others. For the BM@N data, it is planned to use two formats of reconstructed data: the current DST and future miniDST containing only sufficient information for physics analyses. In the last step, various physics analyses of the reconstructed event data are used to investigate the physical properties of the nuclear matter produced at the collisions.

A raw event decoding procedure has been completed and fully integrated into the BmnRoot framework. The decoding consists of two base procedures, converter and decoder, as a whole. The converter is used to get recorded raw data and extract information on DAQ-digits (ADC, TDC, HRB, TQDC, etc.) in accordance with the given Data Acquisition format, which is written to a ROOT tree. The decoder reads DAQ-digits from the tree to process them taking into account

mapping for the detectors. The final output of the data decoding procedure is a file containing digits considered as “physical” ones for all detectors participated in the procedure.

The track reconstruction procedure for the BM@N experiment consists in finding track seeds in the inner tracker system (GEM and silicon planes) and then extending them with the Kalman filter to other detectors of the outer tracker. BmnRoot algorithms to reconstruct parameters of charged particle tracks are based on cellular automaton. A set of quality assurance tests done with the help of Monte Carlo input showed reasonable values of tracking efficiency and good precision of primary vertex reconstruction. A contribution of the silicon part of the inner tracker looks really important when reconstructing the primary vertex.

The BmnRoot framework also includes a tool for event navigation, inspection and visualization. The BM@N event display based on the ROOT EVE package was developed to provide users with a control and graphical representation of detector geometries together with simulated or experimental data, such as MC tracks and their points, as well as reconstructed tracks, hits and calorimeter towers. It offers full interactivity and delivers an easy way to navigate through the events, select a convenient representation and make cuts on energy and particles, to choose objects to be presented on the screen, configure object parameters and other visualization settings.

For visual control of the ongoing BM@N experiment, the Online Histogramming system has been developed as a part of the BmnRoot framework. The system implements decoding of the incoming raw event data, preprocessing and visualization of the calculated histograms. The histograms are transferred via the CERN jsROOT library to the HTTP server viewed by any web-browser in the control room. Users can monitor any detector subsystem, select specific detector plane or station, time or strip profile histograms in 1/2/3D view.

Automation of a modern experiment is impossible without using information systems, which allows collecting, storing, processing and analyzing a large amount of information and simultaneously service a large number of data requests from users and systems of the experiment. To solve the task, a complex of the information systems built on modern databases and supported by RFBR grant is developed and deployed, which automates the processes of online and offline data processing and provides a set of convenient information services for collaboration members. The information systems solve the issues of unified access and data management, ensure correct multi-user processing, actuality, integrity and consistency of the required information, as well as provide automatic data backup to address the possibility of software errors or hardware failures.

The BM@N Condition Database was developed on PostgreSQL as comprehensive data storage for offline data processing. It stores information on the BM@N runs, recorded experimental data, as well as detectors, arbitrary parameters of different types (configuration, calibration, parameter, algorithm) and simulation files obtained by event generators. The BmnRoot environment uses the developed database interface to get information for detector simulation, raw data processing, event reconstruction and physics analysis tasks. The Web interface of the Condition Database provides convenient viewing and changing the data of the experiment over the Web, and visualizing summary statistical information on the BM@N conducted runs.

A new information system, the Electronic Logbook Platform has been designed and implemented to automate the process of recording information during experiment runs, which describes the current parameters of operation modes and states of experiment subsystems, as well as various types of occurred events, encountered problems and their solutions, which are written to the logbook by shift operators of the BM@N experiment. Further the logbook data are used in digitization, processing and physics analysis of the obtained events.

The information system based on the Geometry Database has been developed and now is being deployed to store and process information on the composition and structure of the BM@N detectors used in the runs of the experiment and provides them for the further reconstruction and physics analysis of simulated and experimental data. In addition, the system is aimed at supplying information on the geometry of the setup for online monitoring and offline visualization of BM@N

collision events. Other information systems, such as the Event Metadata System, which provides an event catalogue containing information on summary properties of obtained events and references to their storage location, and ensures quick search for a set of events required for particular physics analysis, and the Configuration Information System to store and provide data on the configuration of the experiment systems when collecting data in online, are under development now.

Mass production of simulation, raw data digitization, event reconstruction and physics analysis tasks are performed offline at distributed systems of the experiment. For distributed data processing of the BM@N events, three computing platforms are currently employed. The Central Information and Computer Complex (CICC) in the Laboratory of Information Technologies provides two queues (Torque scheduler) in small parts of the Tier-1 and Tier-2 centres (on average is about 300 cores for BM@N). The EOS mass storage of the CICC complex is allocated with 1 PB space for the experiment. The Govorun supercomputer is a new part of the HybriLIT heterogeneous platform, which is a computing element of the CICC JINR aimed at acceleration of theoretical and experimental research at JINR. BM@N data processing tasks are also solved via the SLURM scheduler on the Intel Xeon queue of the Govorun containing about 400 logical cores. The NICA in the Laboratory of High Energy Physics provides 1 PB of the EOS distributed file system to organize the data storage for the BM@N experiment, and GlusterFS weekly storage. The Sun Grid Engine scheduling system of the cluster distributes user jobs limiting the number of running tasks to 400 per user, as well as for BM@N mass production.

All required packages, such as, FairSoft, FairRoot, BmnRoot, have been deployed and configured on a central software CVMFS repository of the CICC complex, which is accessible on all the cluster platforms (except the NICA cluster) for distributed processing of the BM@N data. The distributed computing platforms have been used to perform full reconstruction, that is obtaining reconstructed data for all source raw data files, for the conducted BM@N Runs. But the feature of the current computing platforms is that they provide different batch systems and separated data storages. To combine all the resources into one computing processing system, workflow services for distributed BM@N data processing shown in Figure 3.9.2 are being implemented.

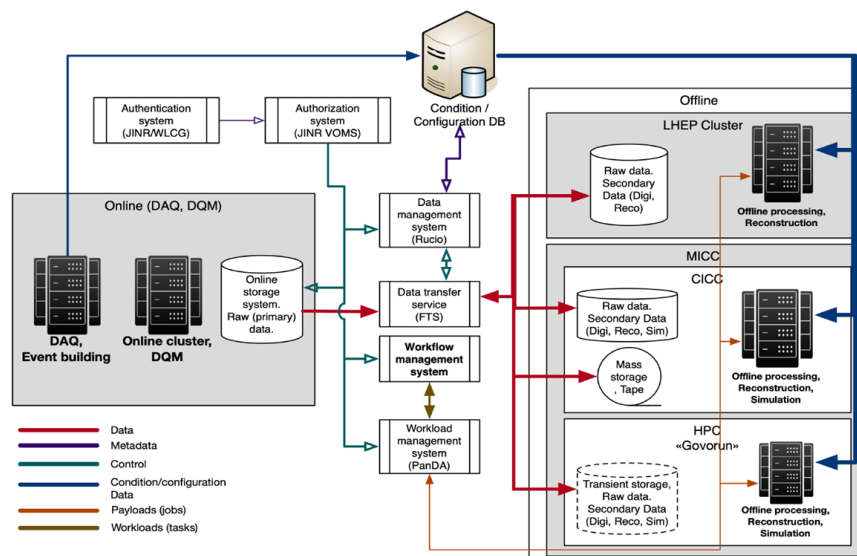

Fig. 3.9.2. Distributed workflow scheme for the future BM@N Runs

Simulation of the future BM@N data processing flow based on a probabilistic approach is urgent task under implementation. The aim of the simulation is to determine a number of computing resources that ensure the operability of the data storage and processing systems. The preliminary results obtained for the current configuration of the BM@N experiment show that for one month of the BM@N operation a storage size of approximately 340 TB is required for raw data and 85 TB to save reconstructed digits and DST files (3 software versions). Assuming 4 months of BM@N operation per year, the distributed storage should allow allocating up to 1.7 PB per year for BM@N data. In addition, it is important to note that the size of BM@N event is directly proportional to

multiplicity, which is a function of interaction centrality. Furthermore, the amount of data taken in experimental runs varies with the detector setup, collision system and trigger conditions.

3.10 Experimental zone

A reference metrological grid of the BM@N experimental zone was created by specialists of Industrial Measurements by a set of 3D measurements. The following works have been performed: the full BM@N coordinate system is fixed; measurements of the coordinates of reference marks and basic elements have been made; measurements of the relative positions of the BM@N elements have been done. For realization of the physical program with heavy ion beams with intensities few 10^6 ion/s additional reinforced concrete blocks for the personnel biological protection should be installed.

3.10.1 Vacuum beam pipe within BM@N

A vacuum beam pipe will be integrated into the experimental setup to minimize the amount of scattering material on the way of heavy ion beam. The beam pipe will consist of three parts: section before the target, inside the analyzing magnet and after the analyzing magnet. The beam pipe before the target is produced from stainless steel and consists of standard vacuum modules and boxes for the beam detectors (Fig.3.10.1).

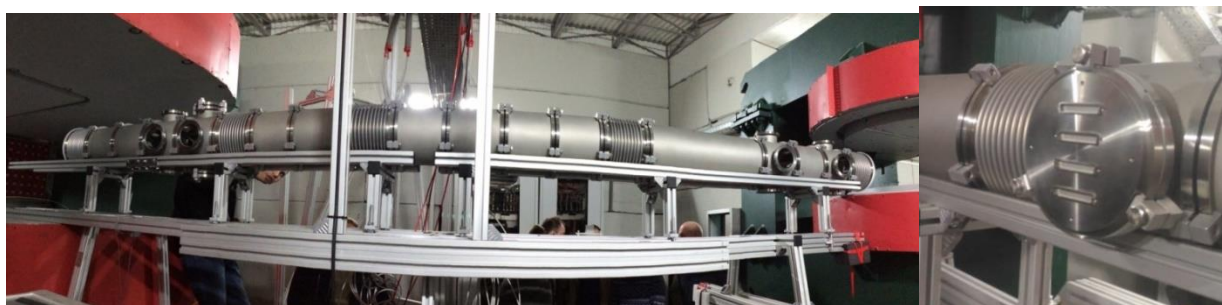

Figure. 3.10.1. Beam pipe before the target and boxes for the beam detectors.

This configuration of the beam pipe was designed and manufactured and tested by LLC “Vacuum systems and technologies” (Belgorod, Russia).



Figure. 3.10.2. Target station. Photo (left, center) and 3D model (right).

After the 1st beam pipe section the target station will be located. It allows us to expose 4 film targets and interchange the targets without breaking the vacuum using the pneumatic cylinders produced by FESTO. The model and photo of the target station are presented at Fig.3.10.2.

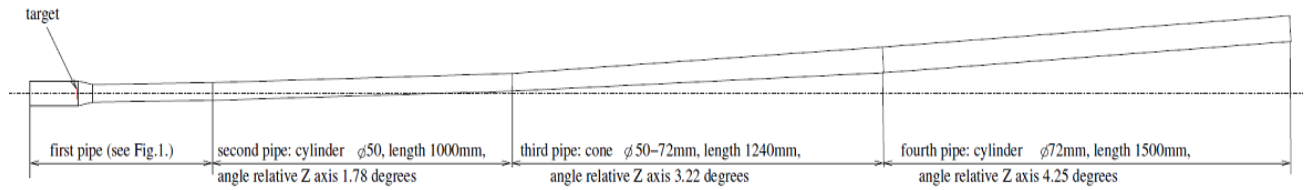

Figure.3.10.3 Technical design of the carbon beam pipe to be placed inside the analyzing magnet.

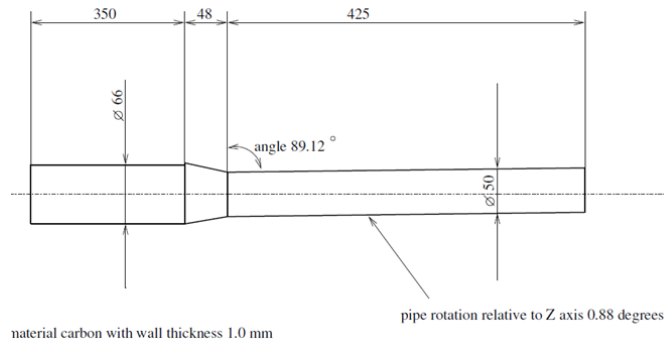

Figure.3.10.4 Technical design of the first section of the carbon beam pipe.

A carbon beam pipe will be installed inside the analyzing magnet. It will consist of four parts shown in Fig.3.10.3 and Fig.3.10.4. Such configuration allows us to install different set-ups of tracking detectors using demountable flangeless connectors (Fig.3.10.5). The total length of the carbon beam pipe is 5 m. The thickness of the walls is 1 mm. It is design to sustain vacuum up to 10^{-3} Torr.

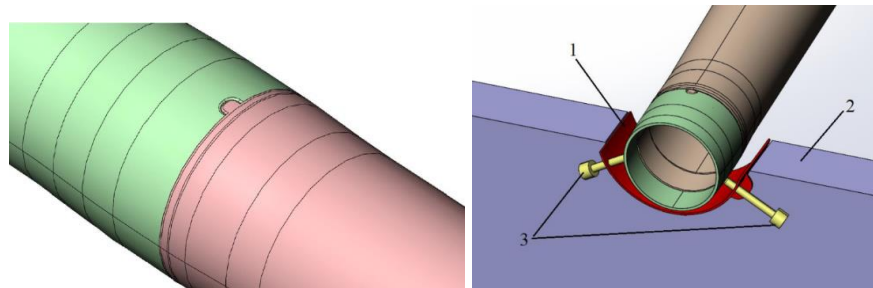

Figure.3.10.5. 3D models of the dismountable flangeless connection (left) and the support scheme of the carbon beam pipe in the GEM beam hole (right).

The beam pipe after the analyzing magnet will be made of aluminum with a diameter of 125 mm and a wall thickness of 1 mm. The 3D model configuration of the beam pipe behind the analyzing magnet is shown in Fig.3.10.6.

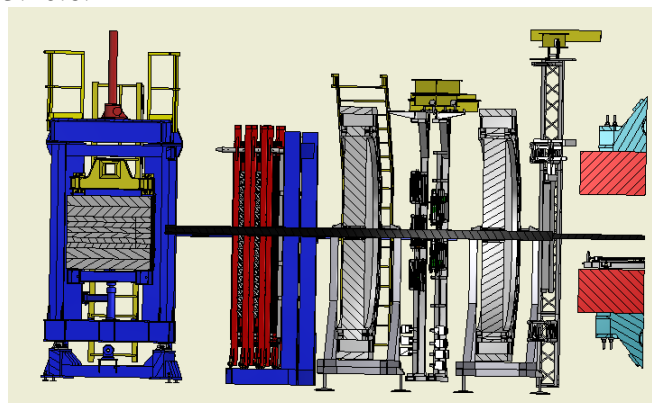

Figure.3.10.6. 3D model configuration of the beam pipe behind the analyzing magnet.

3.10.2 Radiation protection simulation

The simulated geometrical configuration of the BM@N experimental zone is shown in Fig. 3.10.7. It consists of the following components:

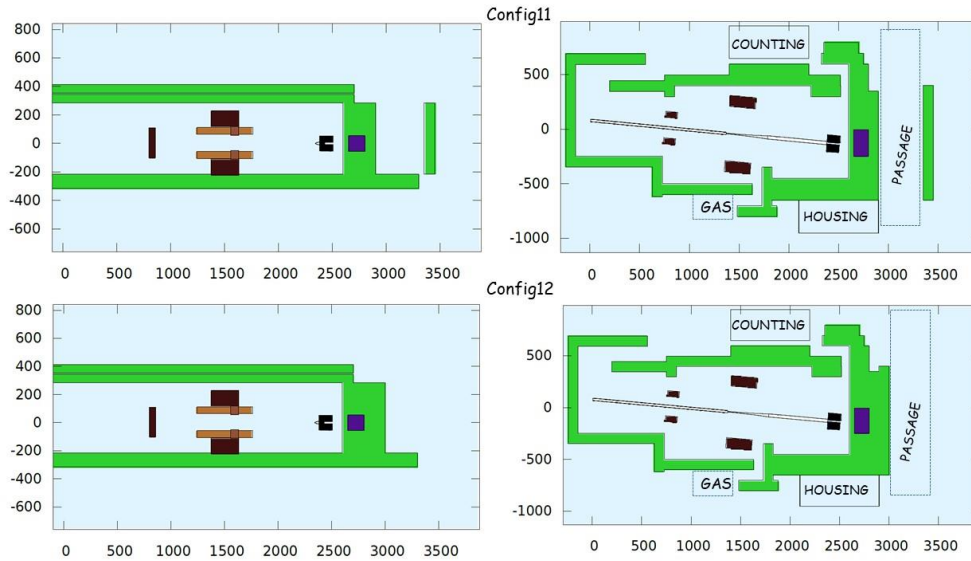

Figure 3.10.7. Two options for the construction of the BM@N concrete protection. Config11 (top) - a variant with a gap in the concrete protection in the PASSAGE zone, Config12 (below) - a variant with continuous concrete protection in the PASSAGE zone. On the left, vertical sections (at the level of the beam dump) of the calculated geometry of the installation are shown. On the right, horizontal sections (at the level of the beam pipe) of the calculated geometry of the installation are shown and the main visiting zones are marked (PASSAGE - personnel passage area, COUNTING and HOUSING - personnel accommodation areas during the experiment, GAS - personnel short-term visit area).

- Target: a cylinder with a radius of 15 mm and a length of 1.06 mm;
- Vacuum beam pipe: Carbon tube 1 mm thick, inside the SP41 magnet;
- Beam dump: Steel-15, parallelepiped with dimensions of $1.6 \times 2.45 \times 1.1 \text{ m}^3$, installed inside a concrete wall at a depth of 50 cm from the edge;
- Two magnets: analyzing SP41 and bending SP57;
- ZDC calorimeter: layered structure 120 cm long along beam, which consists of following layers: lead (16 mm) and scintillator (4 mm) with the addition of three 2.2 cm steel layers for the screed and with a 15x15 cm beam hole in the center;
- Two staff houses with thin steel walls;
- Biological protection - concrete walls 5 m thick with a concrete roof 1.2 m thick. The walls in two versions (see Fig. 3.10.7) near the beam dump (PASSAGE personnel passage area) are considered. The calculation results are presented in Fig. 3.10.8. Taking into account the $6 \mu\text{Sv/h}$ required equivalent dose for category A personnel, the calculations confirm the advisability of choosing a configuration with continuous concrete protection in the personnel passage area, as well as the possibility of installing a concrete roof.

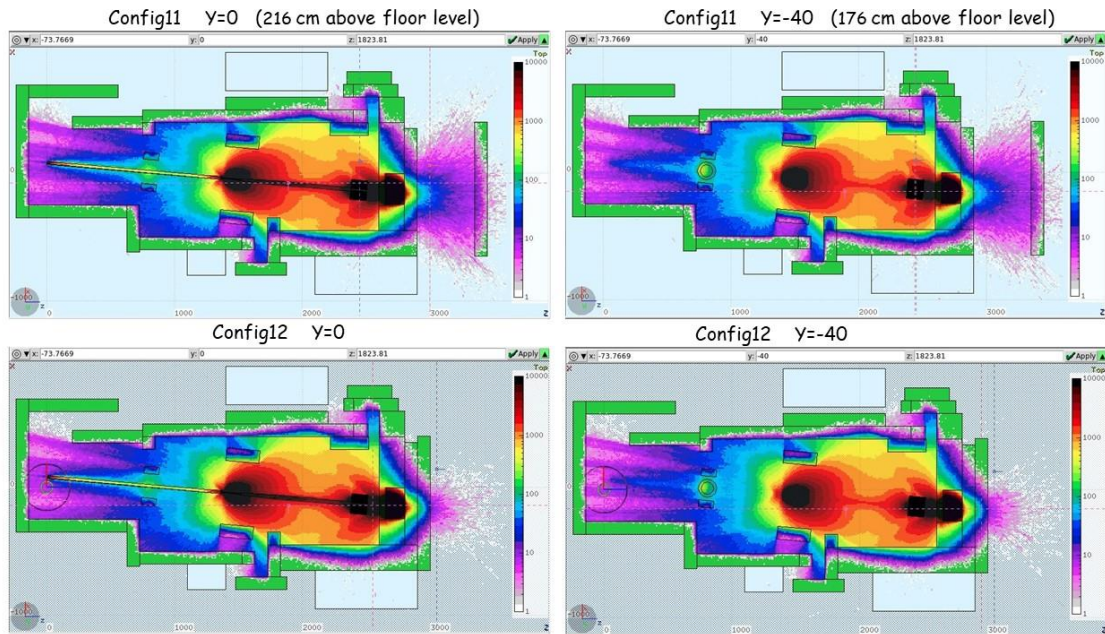

Figure 3.10.8. The distribution of the equivalent dose rate ($\mu\text{Sv/h}$) in the horizontal plane at the beam pipe level ($Y=0$; left) and at a height of 176 cm from the floor level ($Y=-40$; right), is calculated on a grid with a step of 10 cm along each coordinate axis. Config11 (above) corresponds to the version with a gap in the concrete protection in the PASSAGE zone, Config12 (below) corresponds to the continuous concrete protection in the PASSAGE zone. The statistics are 185,000 primary particles.

3.10.3 Spectrometrical Magnet

The measured map of the magnetic field of the SP-41 analysing magnet is illustrated in Fig.3.10.9.

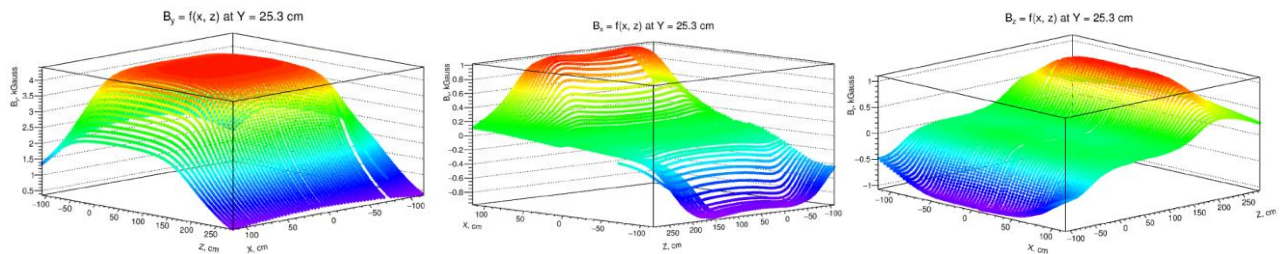

Figure 3.10.9. Two dimensional (X-Z) distributions of the magnetic field components B_y , B_x , B_z (kGauss) measured in the horizontal plane at $Y=25$ cm from the magnet median plane.

3.10.4 Beam line to BM@N

The details of the beam line from the Nuclotron to the BM@N experiment are described in the document [3.10.1]. Horizontal and vertical beam size envelopes (2σ) before and in the BM@N area are shown in Fig.3.10.10. The horizontal and vertical profiles of the krypton beam at 1 m in front of the target are also given. The measured angular spread of the deuteron beam in horizontal and vertical projections is illustrated in Fig.3.10.11. The X / Y sizes (sigma) of the carbon, argon and krypton beams measured at 1 m in front of the target in the BM@N technical runs are summarized in the table below.

C^{12} 2017	Ar 2018	Kr 2018
$\sigma_X = 6$ mm	5 mm	5.3 mm
$\sigma_Y = 4.9$ mm	5 mm	3.2 mm

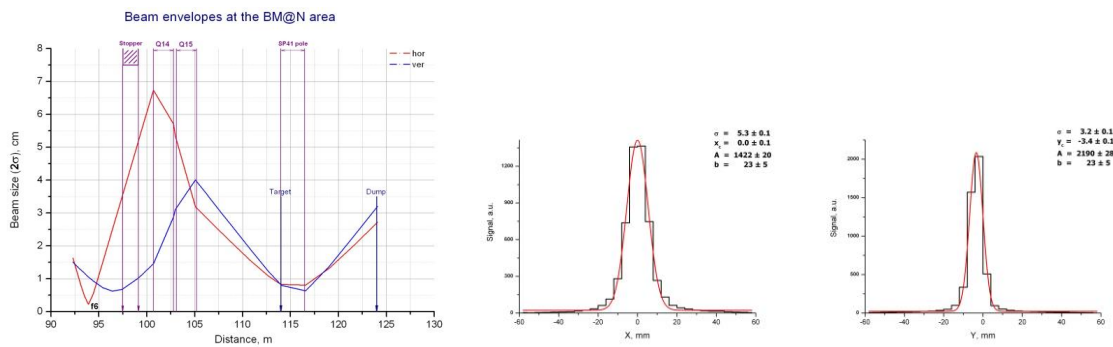

Figure 3.10.10. Left plot: Horizontal and vertical beam size envelopes (2σ) in the BM@N area. The positions of the target, the edges of the pole of the spectrometrical magnet and the beam dump are shown. Central and right plots: Horizontal and vertical profiles of the krypton beam at 1 m in front of the target.

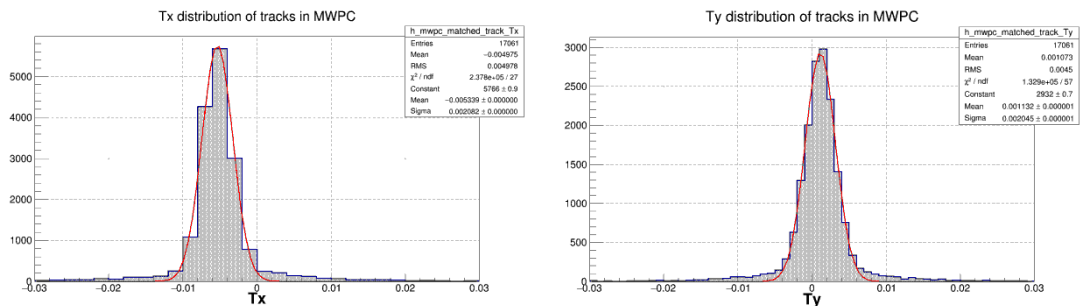

Figure 3.10.11. Angular distributions (radians) of the deuteron beam in horizontal and vertical projections.

[3.10.1] http://bmnshift.jinr.ru/wiki/lib/exe/fetch.php?media=rukoyatkin_4bmnconseil_01.ppt

4. Estimated uncertainties and risks in the Project

We consider the following uncertainties and risks in the project realization:

- Due to a possible delay with the construction of the full vacuum transport channel from the Nuclotron to BM@N the start of heavy ion beam runs could be postponed. Interactions of the heavy ion beam in the air and beam channel elements could cause unacceptable halo background and a wider spread of the beam for the efficient detector operation. The installation of a collimator would reduce the level of background originated from the transport channel.
- Uncertainty in putting into stable routine operation of the Booster-Nuclotron accelerator complex could cause delay of the start of the heavy ion program
- Putting the NICA collider into operation could limit the capacity of the accelerator division to perform experimental runs at the Booster-Nuclotron complex. As a result the accelerator time requested to fulfill the project goals could be achieved later in time.
- Probable delay and long commissioning phase of the installation and putting into operation of the large aperture silicon tracking system STS. As a result, the high intensity heavy ion beam runs with the final BM@N configuration could be delayed.
- A fast FEE electronics for GEM and CSC readout in the high intensity heavy ion beam runs could be not available due to the delivery restrictions. As a result, BM@N will be operated at the beam intensity of few 10^5 Hz.
- Probable delay in the construction of two big CSC chambers of the outer tracking system. The existing DCH drift chambers could be used instead for the middle weight ion beams.
- The response of the beam silicon and trigger detectors could deteriorate due to high ion fluxes. Spare exemplars of the detectors are foreseen for replacement.

5. Estimated expenditures for the Project

Expenditure items	Total cost / resources	1 year 2022	2 year 2023	3 year 2024	4 year 2025	5 year 2026
Direct project expences						
1. Accelerator, hours	14000	2000	3000	3000	3000	3000
2. Computing (proc*hours) / mln	100	15	15	20	25	25
3. Laboratory workshop, hours	2600	600	600	600	400	400
4. Laboratory design buro, hours	1500	500	300	300	200	200
5. Equipment, materials, kUSD	2670	1250	430	350	330	310
6. Research carried out under contracts, kUSD	250	50	50	50	50	50
7. Traveling allowance, kUSD, including:	750	150	150	150	150	150
a) non-ruble zone countries	250	50	50	50	50	50
b) ruble zone countries	250	50	50	50	50	50
c) protocol-based	250	50	50	50	50	50
Total direct expenses, kUSD	3670	1450	630	550	530	510